



## Mercedes R Class 2009-2011

Visit [MetraOnline.com](http://MetraOnline.com) for more detailed information about the product and up-to-date vehicle specific applications

### KIT FEATURES

- ISO DDIN radio provision
- Painted black

### KIT COMPONENTS

- A) Radio trim panel • B) Radio brackets • C) Radio screws (8) • D) Radio trim panel screws (4)

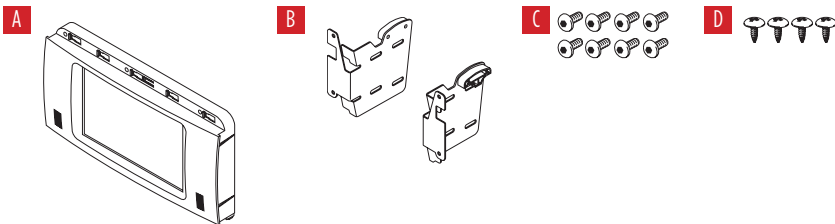

### TABLE OF CONTENTS

Dash Disassembly .....	2
Kit Preparation .....	3
Kit Assembly .....	3

### WIRING & ANTENNA CONNECTIONS (sold separately)

- Wiring Harness: XSVI-9005-NAV (non-amped only)
- Antenna Adapter: 40-EU10
- Steering Wheel Control Interface: • ASWC-1

### TOOLS REQUIRED

- Panel removal tool • Phillips screwdriver
- 3mm Allen screwdriver

**Attention!** Let the vehicle sit with the key out of the ignition for a few minutes before removing the factory radio. When testing the aftermarket equipment, ensure that all factory equipment is connected before cycling the key to ignition.

## DASH DISASSEMBLY

1. Unclip the climate control panel, then set to the side. No need to disconnect the wiring harness. The tabs holding the panel in place are located on the left and right sides of the panel, towards the top. (Figure A)
2. Remove (2) Torx screws below the radio (white circles in figure), then pull down the metal clips to release the radio. Slide the radio out, then unplug and remove the radio. (Figure B)

*Continue to Kit Preparation*

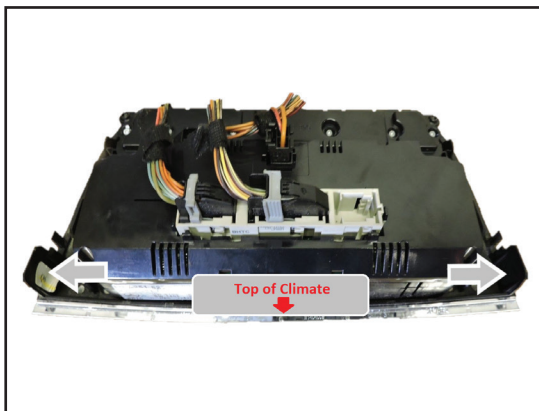

(Figure A)



(Figure B)

## KIT PREPARATION

1. Remove the top trim from the factory radio by pulling back on the release tab in the middle, then sliding the trim to the right. Follow the same procedure to attach it to the **radio trim panel**. (Figure A)
2. Secure the **radio brackets** to the **radio trim panel** using the **(4) radio trim panel screws** supplied. (Figure B)

*Continue to Kit Assembly*



(Figure A)

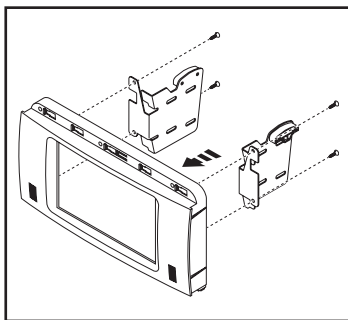

(Figure B)

## KIT ASSEMBLY

1. Slide the radio into the **bracket/panel** assembly, then secure the radio using either the screws supplied with the radio, or the **radio screws** provided. (Figure A)
2. Locate the factory wiring harness and antenna connector in the dash and complete all necessary connections to the radio. Metra recommends using the proper mating adapter from Metra and/or Axxess. Test the radio for proper operation.
3. Slide the radio into the dash, then push the metal clips up into the bottom of the kit. Using the factory Torx screws, secure the metal clips to the dash to secure the radio assembly.
4. Clip the climate control panel back in to complete the installation.

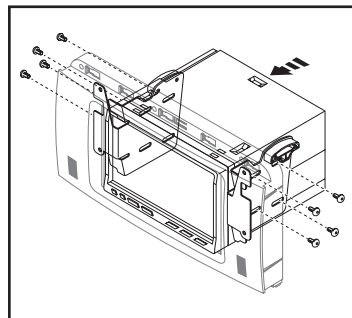

(Figure A)



**95-8728B**  
INSTALLATION INSTRUCTIONS



If you are having difficulties with the installation of this product, contact our Tech Support line either by phone at **1-800-253-TECH**, or email at **techsupport@metra-autosound.com**. Before doing so, look over the instruction booklet a second time and ensure that the installation was performed exactly as the instruction booklet is stated. Have the vehicle apart and ready to perform troubleshooting steps before contacting Metra/Axxess Tech Support.



**KNOWLEDGE IS POWER**

Enhance your installation and fabrication skills by enrolling in the most recognized and respected mobile electronics school in our industry. Log onto [www.installerinstitute.com](http://www.installerinstitute.com) or call 800-354-6782 for more information and take steps toward a better tomorrow.



**Metra recommends MECP certified technicians**