



### BMW X5 (without MOST® Amp) 2007-2013

Visit [MetraOnline.com](http://MetraOnline.com) for more detailed information about the product and up-to-date vehicle specific applications

#### KIT FEATURES

- ISO DDIN radio provision
- Includes all necessary data interfaces, wiring harnesses, and antenna adapter, for a complete installation
- Includes components necessary to relocate the factory climate control and lower button panel
- Painted black to match the factory dash

#### KIT COMPONENTS

- A) Radio trim panel • B) Radio brackets • C) Radio screws (8) • D) Button housing • E) Button housing brackets • F) Phillips screws (2)
- G) ASWC-1 interface and wiring harness (not shown) • H) Axxess interface and wiring harness (not shown) • I) Antenna adapter (not shown)
- J) Chime retention interface and speaker (not shown)

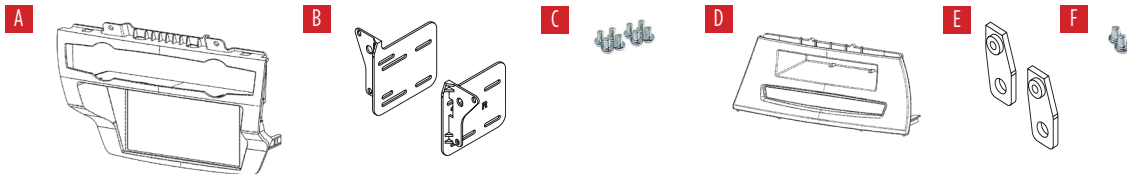

#### TABLE OF CONTENTS

Dash Disassembly .....	2
Kit Preparation .....	3
Kit Assembly .....	4
Axxess Interface Installation.....	5
Final Assembly.....	9

#### WIRING & ANTENNA CONNECTIONS

- Wiring Harness: Included with kit
- Antenna Adapter: Included with kit
- Steering Wheel Control Interface: Included with kit

#### TOOLS REQUIRED

- Panel removal tool • Phillips screwdriver
- 3mm Allen screwdriver

**Attention!** Let the vehicle sit with the key out of the ignition for a few minutes before removing the factory radio. When testing the aftermarket equipment, ensure that all factory equipment is connected before cycling the key to ignition.

## DASH DISASSEMBLY

1. Unclip, unplug, and remove the a/c vent panel. (Figure A)
2. Remove (2) screws securing the upper display, then unclip and remove the display. (Figure B)
3. Remove (2) screws securing the climate panel, then unclip and remove the panel. The panel wraps around the radio and includes the lower buttons. Figure D shows the panel removed for reference. (Figures C & D).
4. Remove (2) screws securing the radio. Slide the radio out, then unplug and remove the radio. (Figure D)

*Continue to Kit Preparation*



(Figure A)



(Figure C)



(Figure B)



(Figure D)

## KIT PREPARATION

1. Unplug the lower button panel from the climate controls. (Figure A)
2. Unclip and remove the climate controls and lower button panel from the factory climate panel, then attach them to the radio trim panel and climate control panel. (Figure B)
3. Remove (2) panel clips from the factory climate panel, then attach them to the radio trim panel.
4. Secure the button housing brackets to the button housing using (2) Phillips screws provided. (Figure C)
5. Secure the button housing assembly to the vehicle using the factory screws, then route the harness downward.

*Continue to Kit Assembly*

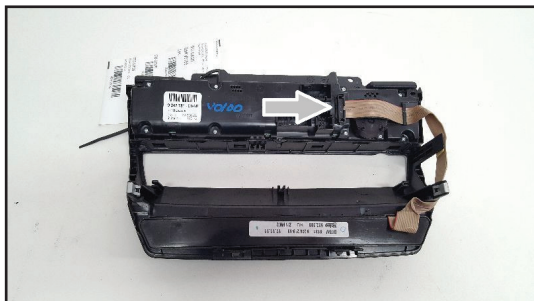

(Figure A)

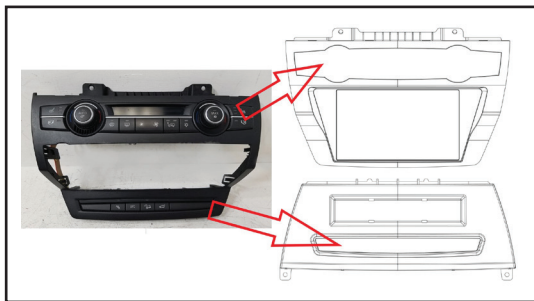

(Figure B)

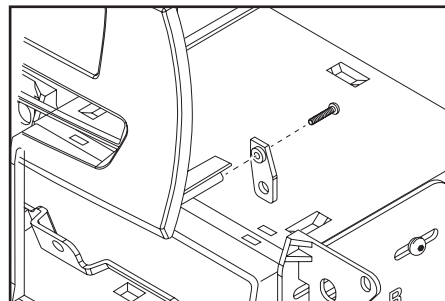

(Figure C)

## KIT ASSEMBLY

1. Secure the **radio brackets** to the radio using either the screws supplied with the radio, or the **radio screws** provided. (Figure A)

*Continue to Axxess  
Interface Installation*

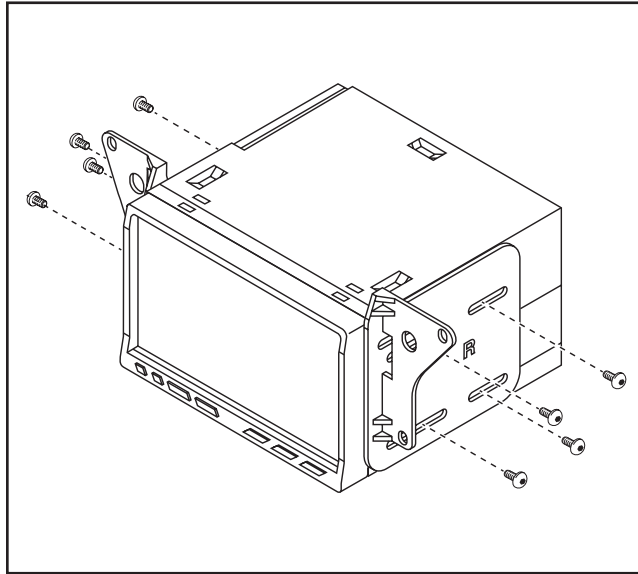

(Figure A)

# AXXESS INTERFACE INSTALLATION

## INTERFACE FEATURES

---

- Provides accessory power
- Retains audio/phone<sup>†</sup> controls on the steering wheel
- Provides NAV outputs (parking brake, reverse, speed sense)
- Retains warning chimes through an outboard speaker
- Retains balance and fade
- Micro-B USB updatable

<sup>†</sup> Radio dependent

## INTERFACE COMPONENTS

---

- 9321 interface
- 9321 harness
- Chime retention interface
- Chime speaker
- ASWC-1 interface
- ASWC-1 harness
- Female 3.5mm connector with stripped leads

## TABLE OF CONTENTS

---

Connections.....	6
Installation .....	7
Programming.....	8

## TOOLS REQUIRED

---

- Crimping tool and connectors, or solder gun, solder, and heat shrink
- Tape • Wire cutter • Zip ties

## CONNECTIONS

### From the 9321 harness to the aftermarket radio:

- Connect the **Black** wire to the ground wire.
- Connect the **Yellow** wire to the battery wire.
- Connect the **Red** wire to the accessory wire.

**Note:** There will be an accessory wire from the **ASWC-1 harness** to connect as well.

- Connect the **Blue** wire to the amplifier turn-on wire.
- If the aftermarket radio has an illumination wire, connect the **Orange** wire to it.
- Connect the **Brown** wire to the mute wire.
- Connect the **Gray** wire to the right front positive speaker output.
- Connect the **Gray/Black** wire to the right front negative speaker output.
- Connect the **White** wire to the left front positive speaker output.
- Connect the **White/Black** wire to the left front negative speaker output.
- Connect the **Green** wire to the left rear positive speaker output.
- Connect the **Green/Black** wire to the left rear negative speaker output.
- Connect the **Purple** wire to the right rear positive speaker output.
- Connect the **Purple/Black** wire to the right rear negative output.

*The following (3) wires are for multimedia/navigation radios that require these wires.*

- Connect the **Blue/Pink** wire to the speed sense wire.
- Connect the **Green/Purple** wire to the reverse wire, and also to the **Blue/White** wire from the AX-CAM6V.
- Connect the **Light Green** wire to the parking brake wire.
- Connect the 6-foot long **Yellow** wire with a fuse-holder directly to the battery, or to an empty “battery power” cavity in the fuse box.

### From the ASWC-1 harness to the aftermarket radio:

This harness is to be used if the vehicle is equipped with steering wheel controls.

- Connect the **Red** wire to the accessory wire.
- **For the radios listed below:** Connect the **female 3.5mm connector with stripped leads**, to the male 3.5mm SWC jack from the **ASWC-1 harness**. Any remaining wires tape off and disregard:
  - **Eclipse:** Connect the steering wheel control wire, normally **Brown**, to the **Brown/White** wire from the connector. Then connect the remaining steering wheel control wire, normally **Brown/White**, to the **Brown** wire from the connector.
  - **Metra OE:** Connect the steering wheel control Key 1 wire (**Gray**) to the **Brown** wire.
  - **Kenwood or select JVC with a steering wheel control wire:** Connect the **Blue/Yellow** wire to the **Brown** wire.  
**Note:** If the Kenwood radio auto detects as a **JVC**, manually set the radio type to **Kenwood**. Refer to the **Changing Radio Type** document available at [axessinterfaces.com/product/ASWC-1](http://axessinterfaces.com/product/ASWC-1).
  - **XITE:** Connect the steering wheel control SWC-2 wire from the radio to the **Brown** wire.
  - **Parrot Asteroid Smart or Tablet:** Connect the 3.5mm jack into the **AX-SWC-PARROT** (sold separately). Then connect the 4-pin connector from the **AX-SWC-PARROT** to the radio.  
**Note:** The radio must have rev. 2.1.4 or higher software.
  - **Universal “2 or 3 wire” radio:** Connect the steering wheel control wire, referred to as Key-A or SWC-1, to the **Brown** wire from the connector. Then connect the remaining steering wheel control wire, referred to as Key-B or SWC-2, to the **Brown/White** wire from the connector. If the radio comes with a third wire for ground, disregard this wire.  
**Note:** After the interface has been programmed to the vehicle, refer to the manual provided with the radio for assigning the SWC buttons. Contact the radio manufacturer for more information.
- **For all other radios:** Connect the 3.5mm jack from the **ASWC-1 harness** into the jack from the aftermarket radio designated for an external steering wheel control interface. Please refer to the aftermarket radios manual if in doubt as to where the 3.5mm jack should connect to.

# INSTALLATION

## With the key in the off position:

1. Zip tie the **chime speaker** under the dash to a location where it will be heard clearly by the driver, then route the harness to the radio location.
2. Connect the **chime speaker** to the connector on the right side of the **chime retention interface**.
3. Connect the **9321 harness** to the **chime retention interface**.
4. Connect the **9321 harness** to the **9321 interface**, and then to the wiring harness in the vehicle.
5. Connect the **ASWC-1 harness** to the **ASWC-1 interface**, and then to the **9321 interface**.
6. Locate the factory antenna connector in the dash and complete all necessary connections to the radio. Use the antenna adapter provided to adapt the factory antenna connector to the aftermarket radio.

**Note:** Disregard the round connector on the antenna adapter, it will not be used in this application.

**Attention!** If retaining steering wheel controls, ensure that the SWC jack/wire is connected to the radio before proceeding. If this step is skipped, the interface will need to be reset for the steering wheel controls to function.

# PROGRAMMING

1. Press and hold the **Volume Up** button on the steering wheel.
2. Turn the ignition on, the L.E.D. in the **ASWC-1 interface** will start flashing rapidly, which means the **ASWC-1 interface** is looking for the vehicle and the radio.
3. After a few seconds the L.E.D. should stop flashing rapidly, then go out for approximately 2 seconds.
4. After 2 seconds there will be a series of 7 **Green** flashes, some short, and some long. The long flashes represent the wires that are connected from the vehicle to the **ASWC-1 interface**. The 3rd, 4th, 5th, and 6th flashes should be longer.
5. The L.E.D. will pause for another 2 seconds, then flash **Red** up to 18 times depending on which radio is connected to the **ASWC-1 interface**. Refer to the **L.E.D. Feedback** section for more information.
6. This is the end of the auto detection stage. If the **ASWC-1 interface** detected the vehicle and radio successfully, the L.E.D. will light up solid. If not, refer to the troubleshooting documents available at [axessinterfaces.com/product/ASWC-1](http://axessinterfaces.com/product/ASWC-1).
7. Test all functions of the installation for proper operation before reassembling the dash. Refer to the **ASWC-1 Steering Wheel Control** documents available at [axessinterfaces.com/product/ASWC-1](http://axessinterfaces.com/product/ASWC-1) for customizing the buttons, if so desired.

*Continue to Final Assembly*

## L.E.D. Feedback

The (18) **Red** L.E.D. flashes represent the brand of radio the **ASWC-1 interface** believes it is connected to. Each flash count represents a different radio Manufacturer. For example, if you are installing a JVC radio, the **ASWC-1 interface** will flash **Red** (5) times, then stop. Following is a legend that explains which radio Manufacturer corresponds to the flash count provided.

L.E.D. feedback legend

Flash Count	Radio
1	Eclipse (type 1) †
2	Kenwood ‡
3	Clarion (type 1) †
4	Sony / Dual
5	JVC
6	Pioneer / Jensen
7	Alpine *
8	Visteon
9	Valor

Flash Count	Radio
10	Clarion (type 2) †
11	Metra OE
12	Eclipse (type 2) †
13	LG
14	Parrot **
15	XITE
16	Philips
17	TBA
18	JBL

\* If the **ASWC-1 interface** flashes **Red** (7) times, and an **Alpine** radio is not installed, that means an open connection. Verify that the 3.5mm jack is connected to the correct steering wheel jack/wire in the radio.

\*\* The **AX-SWC-PARROT** is required (sold separately). Also, the software in the radio must be rev. 2.1.4 or higher.

† If a **Clarion** radio is installed and the steering wheel controls do not function, change the radio type to the opposite **Clarion** radio type; likewise for **Eclipse**. Refer to the **Changing Radio Type** document available at [axessinterfaces.com/product/ASWC-1](http://axessinterfaces.com/product/ASWC-1).

‡ If a **Kenwood** radio is installed and the L.E.D. feedback comes back showing as a **JVC** radio, change the radio type to **Kenwood**. Refer to the **Changing Radio Type** document available at [axessinterfaces.com/product/ASWC-1](http://axessinterfaces.com/product/ASWC-1).

## FINAL ASSEMBLY

1. Secure the radio assembly to the dash using the factory screws.
2. Connect the button panel harness to the climate controls, then connect the climate controls back to the wiring harness in the vehicle.
3. Clip the **radio trim panel** to the dash, then secure using the factory screws. (Figure A)
4. Reconnect and attach the a/c vent panel back to the vehicle to complete the installation.

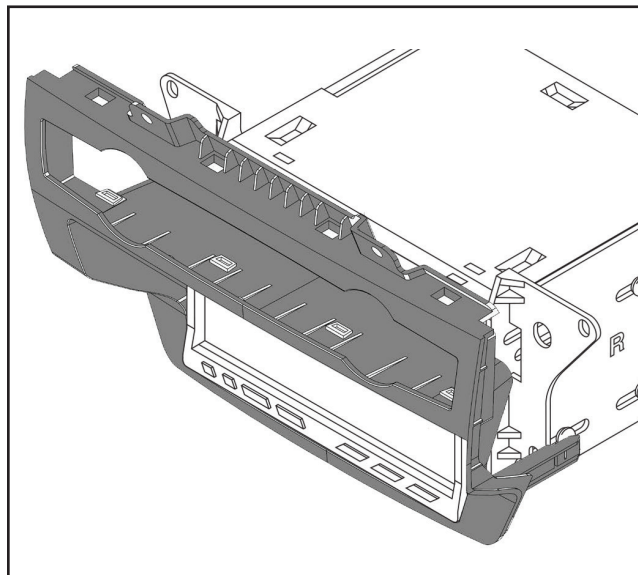

(Figure A)







**95-9321B**  
INSTALLATION INSTRUCTIONS



If you are having difficulties with the installation of this product, contact our Tech Support line either by phone at **1-800-253-TECH**, or email at **techsupport@metra-autosound.com**. Before doing so, look over the instruction booklet a second time and ensure that the installation was performed exactly as the instruction booklet is stated. Have the vehicle apart and ready to perform troubleshooting steps before contacting Metra/Axxess Tech Support.



**KNOWLEDGE IS POWER**

Enhance your installation and fabrication skills by enrolling in the most recognized and respected mobile electronics school in our industry. Log onto [www.installerinstitute.com](http://www.installerinstitute.com) or call 800-354-6782 for more information and take steps toward a better tomorrow.



**Metra recommends MECP certified technicians**