



## INSTALLATION INSTRUCTIONS FOR PART 99-3003

**APPLICATIONS**  
**CADILLAC/CHEVROLET/GMC**  
**(SEE INSIDE FOR SPECIFIC APPLICATIONS)**

# 99-3003

## INSTALLATION INSTRUCTIONS

### KIT FEATURES

- Shaft and DIN Unit Provisions
- Equalizer Provisions

### KIT COMPONENTS

- A) Radio Housing • B) Mounting Clips • C) Equalizer Dummy Plate • D) Tape Strips
- E) (2) Carriage Bolts • F) (2) Keps Nuts

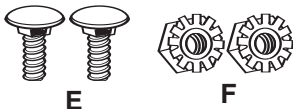
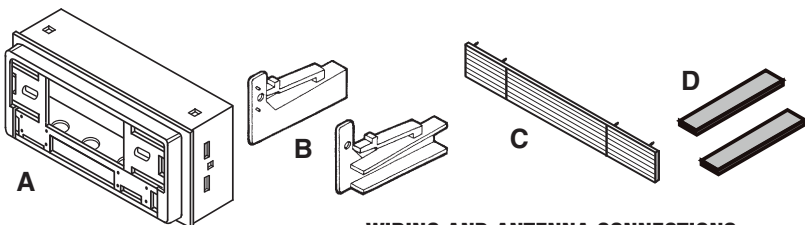

### **WIRING AND ANTENNA CONNECTIONS** **(SOLD SEPARATELY)**

#### **HARNES:**

- 70-1858 - GM harness 87-05

#### **ANTENNA ADAPTER:**

- 40-GM10 - GM antenna adapter 88-up

### TOOLS REQUIRED:

- File • Flat Blade Screwdriver • Socket Wrench • Cutting Tool
- Panel Removal Tool

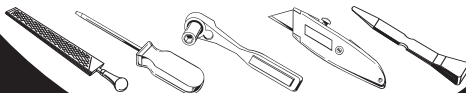

**1-800-221-0932**



**www.metraonline.com**

© COPYRIGHT 2001-2009 METRA ELECTRONICS CORPORATION



**99-3003**

**TABLE OF CONTENTS**

**Kit Preparation ..... 1,2,3**

**Kit Assembly and Final Assembly**

**Shaft Head Unit Mount Radio Provision .....4,5,6**

**DIN Head Unit Mount Radio Provision**

**\*Note:**

**Refer also to the instructions included with the aftermarket radio.**

**APPLICATIONS**

**NOTE: \* THE FACTORY MOUNTING BRACKET(S) MUST BE RETAINED AND USED WITH THIS VEHICLE.**

**CADILLAC**

Escalade 1999-2002  
EXT 2002

**CHEVROLET**

Astro 1996-2005  
Avalanche 2002  
Express (Full size van) 1996-2000  
Pickup (C-Series) 1995-2000  
Silverado 1999-2002  
Suburban 1995-2002  
Tahoe 1995-2002

**GMC**

Safari 1996-1995  
Savana 1996-2000  
Sierra 1995-2002  
Suburban 1995-2002  
Tahoe 1995-2002  
Yukon (All) 1995-2002



**KNOWLEDGE IS POWER**

Enhance your installation and fabrication skills by enrolling in the most recognized and respected mobile electronics school in our industry.

Log onto [www.installerinstitute.com](http://www.installerinstitute.com) or call 800-354-6782 for more information and take steps toward a better tomorrow.

**CADILLAC**
**Escalade 1999-2002 / EXT 2002**
**CHEVROLET**
**Avalanche/C-Series Pickup/Suburban/Tahoe**
**1995-2002 Silverado 1999-2002**
**GMC**
**Sierra/Suburban/Yukon 1995-2002**

- 1 Disconnect the negative battery terminal to prevent an accidental short circuit. Remove the steering column filler panel and the ashtray. Unclip the dash trim bezel and remove. Using a small flat-blade screwdriver, press down on the outer clips of the factory head unit (or pocket). Disconnect the wiring and remove the unit.

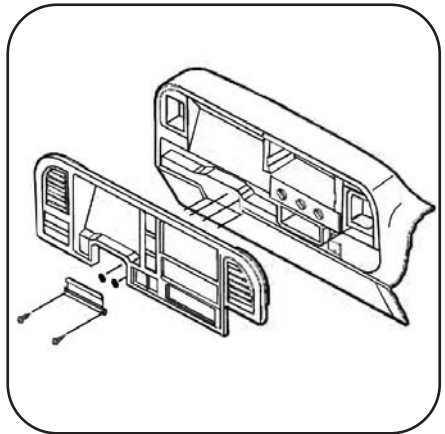
**A**

- 2 Secure the Mounting Clips to the sides of the Radio Housing with (2) Carriage Bolts and (2) Nuts supplied. Skip to the Installation Instructions for ALL VEHICLES on Page #4.

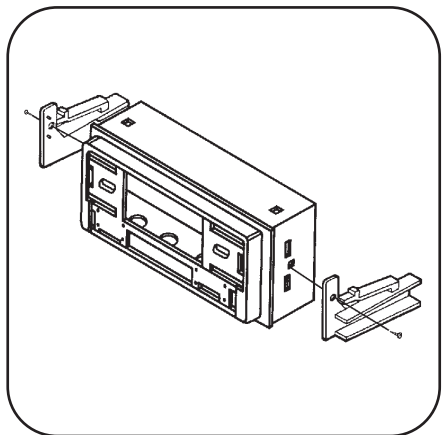
**B**

**CHEVROLET**  
**Express Van (Full Size) 1996-2000**  
**GMC**  
**Savana 1996-2000**

**1** Disconnect the negative battery terminal to prevent an accidental short circuit. Unclip the dash trim bezel. Using a small flat-blade screwdriver, press down on the outer clips of the factory head unit and remove the unit. **(See Fig. A)**

**A**

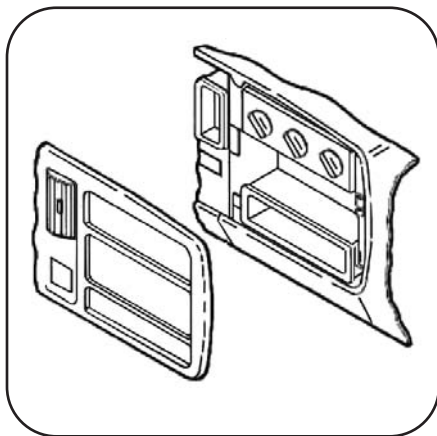

**2** Peel away the paper backings from the Tape Strips and stick the Strips to the lower shelves of the mounting clips. **(See Fig. A in B)** Secure the Mounting Clips to the sides of the Radio Housing with (2) Carriage Bolts and (2) Keps Nuts supplied. **(See Fig. B in B)** Skip to the Installation Instructions for ALL VEHICLES on Page #4.

**B**

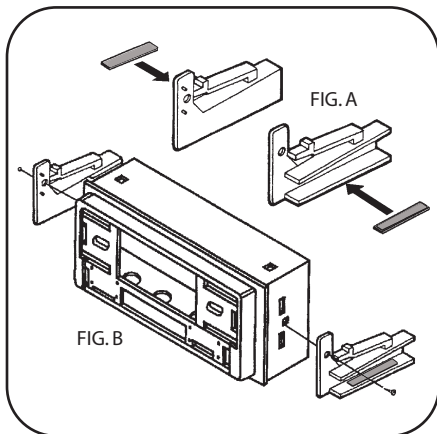

**CHEVROLET**  
**Astro**  
**GMC**  
**Safari 1996-2005**

- 1 Disconnect the negative battery terminal to prevent an accidental short circuit. Place the gear selector in its lowest position. Unclip the perimeter of the dash trim bezel. Disconnect the rear a/c control harness and the headlight switch from the back of the dash trim bezel and remove the bezel. Using a flat-blade screwdriver press down on the outside clips of the factory head unit and remove. **(See Fig. A)**

**A**

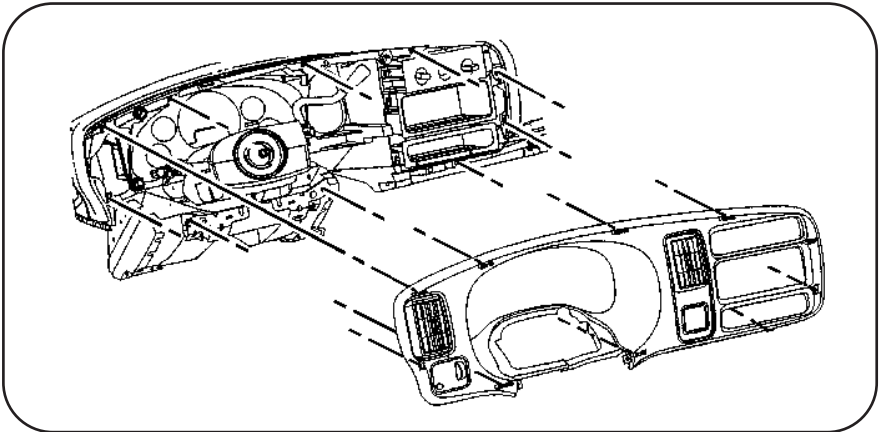

- 2 Peel away the paper backings from the Tape Strips and stick the Strips to the lower shelves of the Mounting Clips. **(See Fig. A in B)** Secure the Mounting Clips to the sides of the Radio Housing with (2) Carriage Bolts and (2) Keps Nuts supplied. **(See Fig. B in B)** Skip to the Installation Instructions for ALL VEHICLES on Page #4.

**B**

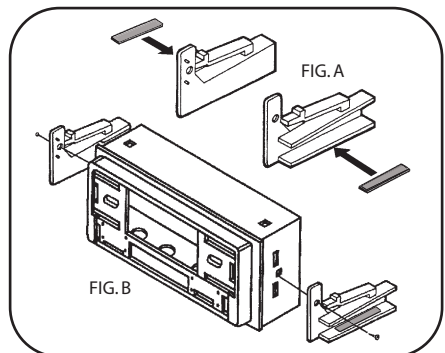

**ALL VEHICLES**

**2-SHAFT HEAD UNITS:** Snap the aftermarket head unit into the kit and secure with shaft nuts. (See Fig. A)

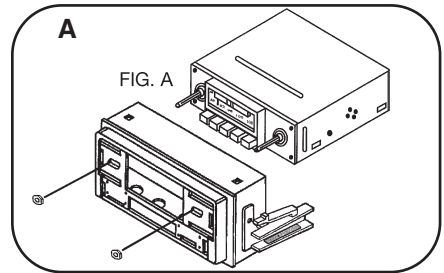

**DIN HEADS UNITS:** Cut and remove the shaft supports from the Radio Housing. Slide the DIN cage into the kit and secure by bending the metal locking tabs down. Slide the aftermarket head unit into the cage until secure. (See Fig. B)

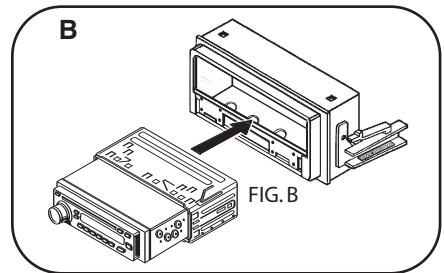

**IF AN EQUALIZER WILL BE INCLUDED:** Cut and remove the supports from the equalizer opening. Slide the aftermarket equalizer into the back of the Radio Housing. Using the hardware included with the equalizer, mount the unit to the kit. (See Fig. A)

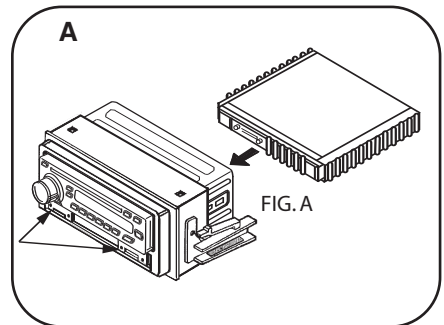

**IF AN EQUALIZER WILL NOT BE INCLUDED:** Slide the aftermarket equalizer Dummy Plate into the Radio Housing. (See Fig. B)

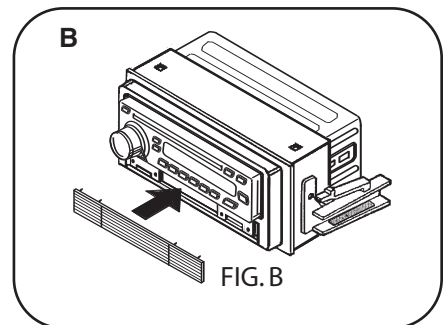

## FINAL ASSEMBLY

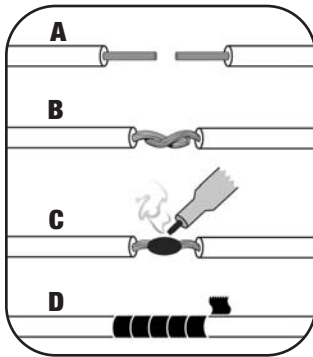

**(A) Strip wire ends back 1/2"**

**B) Twist ends together**

**C) Solder**

**D) Tape**

- 1 Locate the factory wiring harness in the dash. Metra recommends using the proper mating adapter and making connections as shown. (Isolate and individually tape off the ends of any unused wires to prevent electrical short circuit.)
- 2 Re-connect the negative battery terminal and test the unit for proper operation.
- 3 Reassemble radio and dash assemblies in reverse order of disassembly.

### FINAL WIRING CONNECTIONS

Make wiring connections using the EIA color code chart shown below and the instructions included with the head unit. Metra recommends making connections as shown below; Strip, Splice, Solder, Tape. Isolate and individually tape off ends of any unused wires to prevent electrical short circuit.

#### METRA / EIA WIRING CODE

12V Ignition / Acc. . . . .	Red	Right Front (+) . . . . .	Gray
12V Batt / Memory . . . . .	Yellow	Right Front (-) . . . . .	Gray/ Black
Ground . . . . .	Black*	Left Front (+) . . . . .	White
Power Antenna . . . . .	Blue	Left Front (-) . . . . .	White / Black
Amp Turn-On . . . . .	Blue / White	Right Rear (+) . . . . .	Violet
Amp Ground . . . . .	Black / White	Right Rear (-) . . . . .	Violet / Black
Illumination . . . . .	Orange	Left Rear (+) . . . . .	Green
Dimmer . . . . .	Orange / White	Left Rear (-) . . . . .	Green / Black

**\*NOTE:** When a Black wire is not present, ground radio to vehicle chassis.  
All colors may not be present on all leads due to manufacturer's specifications.

## ALL VEHICLES

Using a file, remove 1/32" from the top and bottom edges of the dash trim bezel radio opening. (See Fig. A) Insert the head unit/kits assembly into opening (through the back of the bezel) to insure proper clearance has been established.

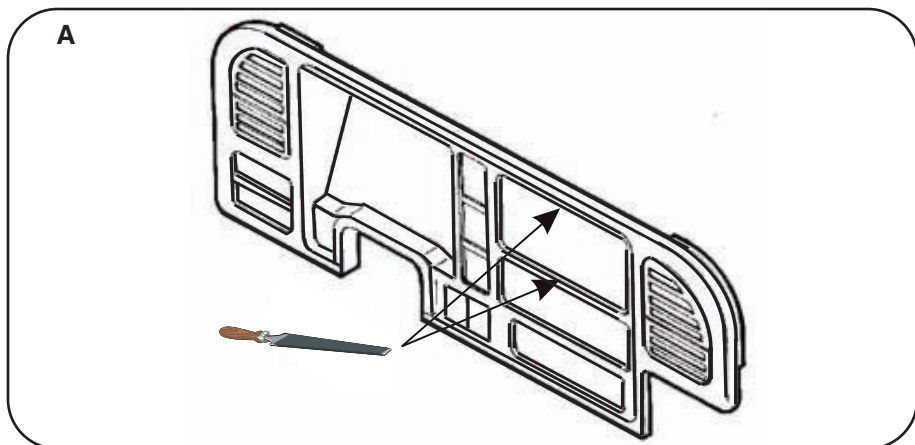

Re-connect the battery terminal and test the unit for proper operation. Mount the head unit/kits assembly to the sub-dash with those screws previously removed.  
*Enjoy your newly installed radio!*

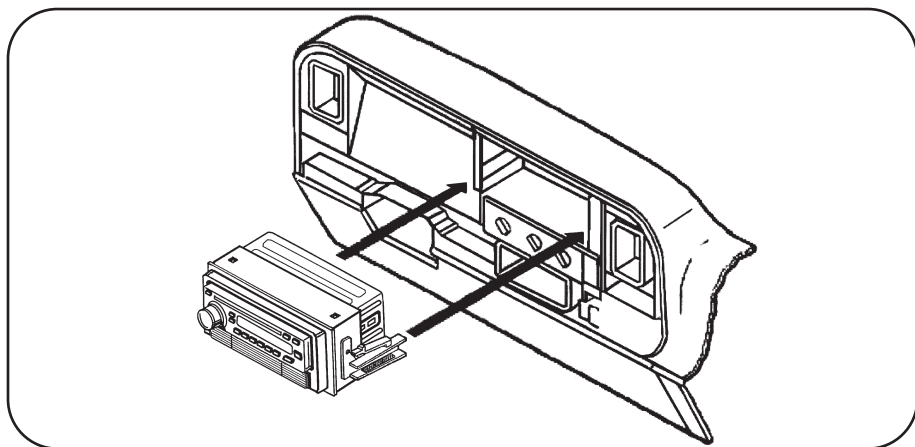

1-800-221-0932



[www.metraonline.com](http://www.metraonline.com)