

# ALL VEHICLES

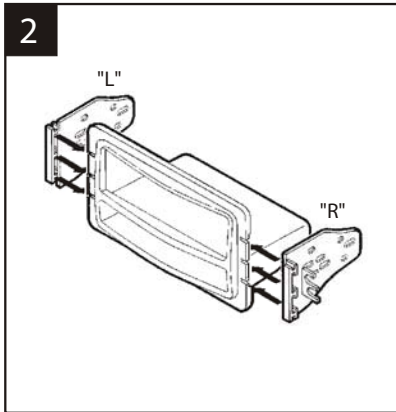

Slide Mounting Brackets ("L" and "R") into the slots on the sides of the Radio Housing as indicated.

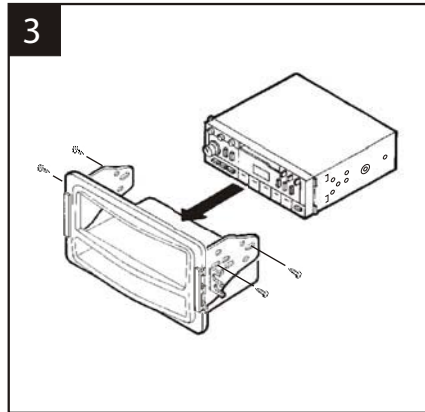

Slide the ISO-DIN head unit into the kit. Align the holes in the Mounting Brackets with the holes in the head unit and mount the Brackets to the head unit with the screws included with the unit.

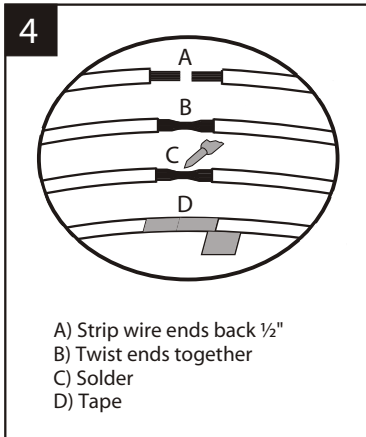

- A) Strip wire ends back 1/2"
- B) Twist ends together
- C) Solder
- D) Tape

Locate the factory wiring harness in the dash. Metra recommends using the proper mating adaptor and making connections as shown. (Isolate and individually tape off the ends of any unused wires to prevent electrical short circuit).

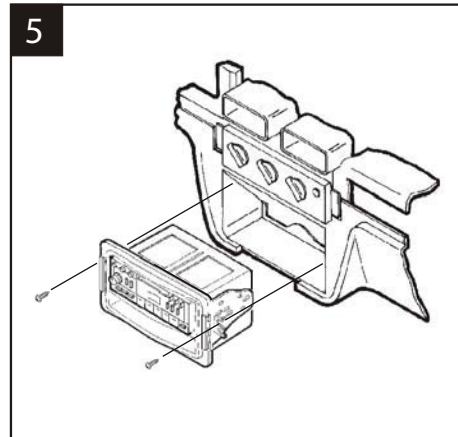

Re-connect the battery terminal and test the unit for proper operation. Mount the head unit/kit assembly to the sub-dash with those screws previously removed in step #1.

REV. 07-29-09

## KIT FEATURES

- ▶ ISO-DIN unit provisions
- ▶ CD pocket holds (2) jewel cases

## KIT COMPONENTS

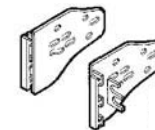
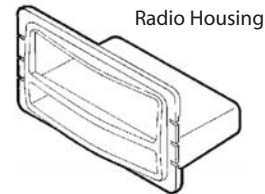

Mounting Brackets

## TOOLS REQUIRED



Phillips screwdriver



Socket wrench



# 99-3301

## INSTALLATION INSTRUCTIONS

### APPLICATIONS

| CAR                        | PAGE |
|----------------------------|------|
| BUICK                      |      |
| Century 1997-2005.....     | 1    |
| LeSabre 1995-2005.....     | 1    |
| Park Avenue 1995-2005..... | 1    |
| Regal 1995-2004.....       | 6    |
| Rendezvous 2002-2007.....  | 6    |
| CHEVROLET                  |      |
| Avalanche 2003-2006.....   | 6    |
| Cavalier 2000-2005.....    | 6    |
| Express Van 2001-2007..... | 5    |
| Impala 2000-2005.....      | 5    |
| Malibu 2001-2003.....      | 5    |
| Monte Carlo 2000-2005..... | 5    |
| Trailblazer 2002-2007..... | 2    |
| Venture 2000-2005.....     | 2    |
| GMC                        |      |
| Envoy 2002-2007.....       | 2    |
| OLDMOBILE                  |      |
| Bravada 1998-2001.....     | 2    |
| Silhouette 2000-2004.....  | 5    |
| PONTIAC                    |      |
| Aztec 2001-2005.....       | 3    |
| Bonneville 2000-2005.....  | 3    |
| Grand Am 2001-2005.....    | 4    |
| Montana 2000-2005.....     | 4    |
| Sunfire 2000-2005.....     | 4    |

### WIRING AND ANTENNA CONNECTIONS (Sold Separately)

**Harness:**  
Please visit [www.metraonline](http://www.metraonline) for specific interface applications

**Antenna adapter:** • 40-GM10 - GM antenna adapter 88-up



**KNOWLEDGE IS POWER**  
Enhance your installation and fabrication skills by enrolling in the most recognized and respected mobile electronics school in our industry. Log onto [www.installerinstitute.com](http://www.installerinstitute.com) or call 800-354-6782 for more information and take steps toward a better tomorrow.

1-800-221-0932 [www.metraonline.com](http://www.metraonline.com)

© COPYRIGHT 2001-2009 METRA ELECTRONICS CORP.

## BUICK Century 1997-2005

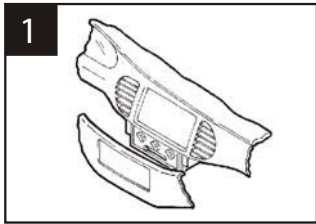

Disconnect the negative battery terminal to prevent an accidental short circuit. Remove the plastic trim piece to the left of the glove box and (1) phillips screw exposed. Unsnap the top edge of the knee bolster panel. Remove (1) phillips screw from the panel. Remove the ashtray cluster and (2) phillips screws from each side. Unclip the entire dash trim bezel and remove. Open doors and unsnap end caps from each side of dash. Unsnap and remove radio/instrument cluster panel. Remove (3) screws in order to remove radio.

## BUICK LeSabre 1995-2005

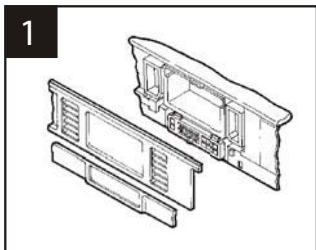

Disconnect the negative battery terminal to prevent an accidental short circuit. Open drivers door and unsnap and remove dash end cap. Remove (2) phillips screws from underneath steering column cover. Unsnap and remove steering column cover. Unsnap and remove instrument panel. Remove (2) 9/32" screws and remove radio.

## BUICK Park Avenue 1995-1999

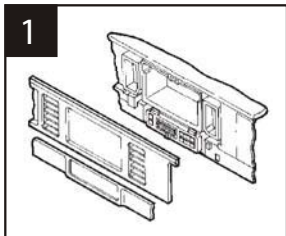

Disconnect the negative battery terminal to prevent an accidental short circuit. Unsnap the climate control trim panel (from door to door) and remove (4) phillips screws exposed. Pop out the a/c vents and remove (1) phillips screw exposed in each vent cavity. Unclip the radio trim bezel and remove. Remove the screws securing the factory head unit and disconnect the wiring.

## BUICK Park Avenue 2000-2005

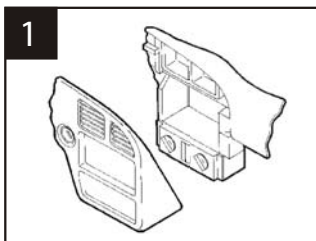

Disconnect the negative battery terminal to prevent an accidental short circuit. Open drivers door and unsnap and remove dash end cap. Remove (2) phillips screws from underneath steering column cover. Unsnap and remove steering column cover. Unsnap and remove instrument panel. Remove (2) 9/32" screws and remove radio.

## BUICK Regal 1995-2000

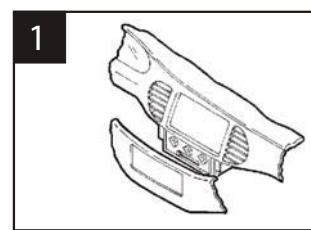

Disconnect the negative battery terminal to prevent an accidental short circuit. Remove the plastic trim piece to the left of the glove box and (1) phillips screw exposed. Unsnap the top edge of the knee bolster panel. Remove (1) phillips screw from the panel. Remove the ashtray cluster and (2) phillips screws from each side. Unclip the entire dash trim bezel and remove. Open doors and unsnap end caps from each side of dash. Unsnap and remove radio/instrument cluster panel. Remove (3) screws in order to remove radio.

## BUICK Rendezvous 2002-2007



Disconnect the negative battery terminal to prevent an accidental short circuit. Remove screws in cup holder. Unsnap and remove shifter. Remove (2) screws from bottom of radio/climate control bezel, unclip and remove. Remove (3) 7mm hex head screws to remove radio.

## CHEVROLET Avalanche 2003-2006



Disconnect the negative battery terminal to prevent an accidental short circuit. Unsnap and remove dash bezel. Remove (3) 9/32" screws and remove radio.

## CHEVROLET Cavalier 2000-2005

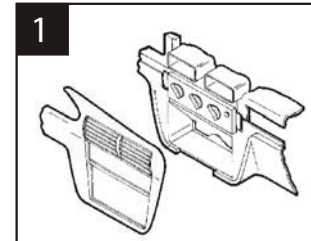

Disconnect the negative battery terminal to prevent an accidental short circuit. Open driver door and remove fuse panel on the end of dash. Open passenger door and remove panel on end of dash. Remove (1) phillips screw from each side exposed. Remove (3) screws from top of glove box liner. Remove (2) screws from the top-left corner of the glove box cavity. Remove (1) phillips screw from the defroster duct. Remove the duct work and (1) phillips screw exposed. Remove the dash pad and (3) phillips screws exposed at the top of the radio trim bezel.

## CHEVROLET Express Van 2001-2007

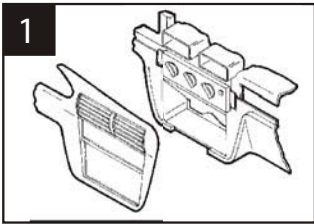

1 Disconnect the negative battery terminal to prevent an accidental short circuit. Remove (2) 10mm bolts from below knee bolster under steering column and remove panel. Remove (2) 10mm bolts from panel below passenger dash airbag and remove panel. Remove (2) 10mm nuts from inside center pocket between power outlets. Unsnap and remove radio and instrument cluster panel. (May not be necessary to completely remove radio and instrument cluster panel to access radio.) Remove (3) 9/32" bolts to remove radio.

## CHEVROLET Impala 2000-2005

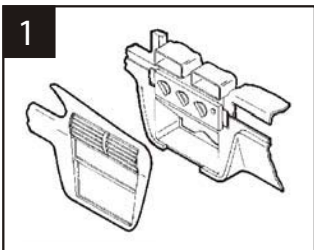

1 Disconnect the negative battery terminal to prevent an accidental short circuit. Open drivers door and remove fuse panel on end of dash. Open passenger door and remove panel on end of dash. Remove (1) Phillips screw from each side exposed. Remove (3) screws from top of glove box liner. Remove (2) screws from the top-left corner of the glove box cavity. Remove (1) Phillips screw from the defroster duct. Remove the duct work and (1) Phillips screw exposed. Remove the dash pad and (3) Phillips screws exposed at the top of the radio trim bezel. Skip to the Installation Instructions for ALL VEHICLES on Page #3.

## CHEVROLET Malibu 2001-2003



1 Disconnect the negative battery terminal to prevent an accidental short circuit. Unsnap and remove radio bezel. Remove (3) bolts and remove radio.

## CHEVROLET Monte Carlo 2000-2005

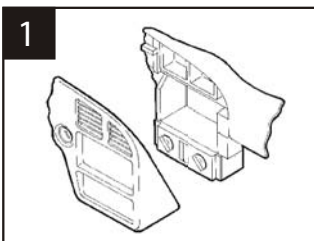

1 Disconnect the negative battery terminal to prevent an accidental short circuit. Unclip the trim panel above the pedals. (It is not necessary to remove the panel, it can remain hanging.) Remove (2) 9/32" screws from the knee panel and unclip the panel. Unsnap the driver's side fuse panel cover and remove (1) 9/32" screw. Open the glove box and remove (1) 9/32" screw from the upper left corner. Remove (3) 9/32" screws securing the factory radio and disconnect the wiring.

## CHEVROLET Trailblazer 2002-2007



1 Disconnect the negative battery terminal to prevent an accidental short circuit. Remove (2) phillips screws inside climate cluster. Remove (1) phillips screw under climate controls to the left of the power outlet. Remove (2) 9/32" screws from under steering column, lower the panel to access (3) phillips screws from around steering wheel and remove. Unsnap and remove bezel. (Use caution pulling over hazard switch.)

## CHEVROLET Venture 2000-2005

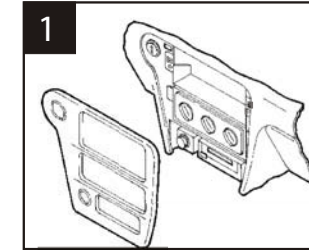

1 Disconnect the negative battery terminal to prevent an accidental short circuit. Open cup holders and remove (2) phillips / 7mm screws. Unsnap and remove dual power outlet assembly from lower storage. Open lower storage door and remove (2) 7 mm screws inside. Remove (2) 7mm screws (facing up) from under cup holder. Remove (3) 7mm hex head screws and remove radio.

## GMC Envoy 2002-2007



1 Disconnect the negative battery terminal to prevent an accidental short circuit. Remove the climate control knobs. Remove (1) phillips screw above and (2) phillips screws below the climate controls. Unclip the radio trim bezel. Remove (4) screws from the factory head unit, slide the unit out and disconnect the wiring.

## OLDSMOBILE Bravada 1998-2001



1 Disconnect the negative battery terminal to prevent an accidental short circuit. Unsnap top trim of floor console and slide back. Remove (4) phillips screws: (2) left and (2) right lower from the carpeted panel. Slide carpeted panel down and backwards to reveal (2) phillips screws and remove. Unsnap radio bezel and unplug cigarette lighter and accessories. Remove (3) 7mm screws and remove radio.

## OLDSMOBILE Silhouette 2000-2004

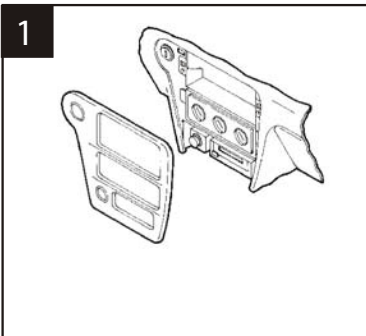

Disconnect the negative battery terminal to prevent an accidental short circuit. Open cup holders and remove (2) phillips 7mm screws. Unsnap and remove dual power outlet assembly from lower storage. Open lower storage door and remove (2) 7mm screws inside. Remove (2) 7mm screws (facing up) from under cup holder. Remove (3) 7mm hex head screws and remove radio.

## PONTIAC Grand Am 2001-2005

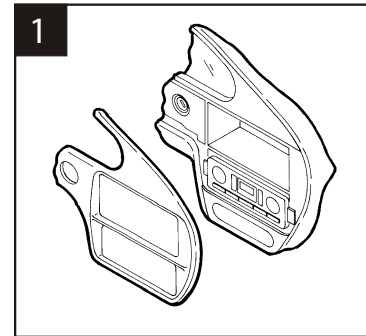

Disconnect the negative battery terminal to prevent an accidental short circuit. Unsnap and remove radio trim bezel. Remove (3) 9/32" screws from radio brackets and remove radio.

## PONTIAC Aztec 2001-2005

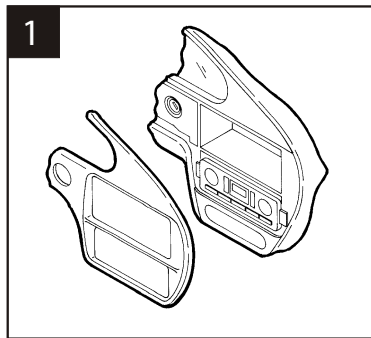

Disconnect the negative battery terminal to prevent an accidental short circuit. Pull out cup holder inserts. Remove (1) phillips screw exposed inside bottom cup holder. Unsnap and remove shifter trim with cup holders. Remove (2) #15 torx at bottom of radio / climate bezel.

## PONTIAC Montana 2000-2005

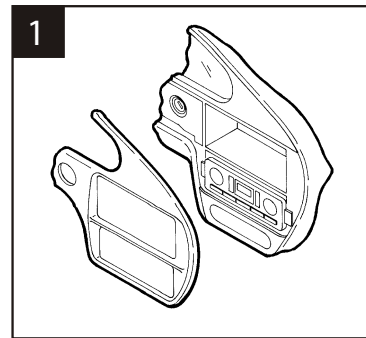

Disconnect the negative battery terminal to prevent an accidental short circuit. Open cup holders and remove (2) phillips 7mm screws. Unsnap and remove dual power outlet assembly from lower storage. Open lower storage door and remove (2) 7mm screws inside. Remove (2) 7mm screws (facing up) from under cup holder. Remove (3) 7mm hex-head screws and remove radio.

## PONTIAC Bonneville 2000-2005

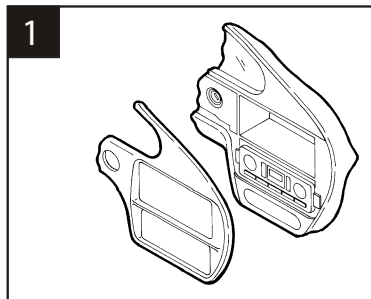

Disconnect the negative battery terminal to prevent an accidental short circuit. Remove (2) phillips screws from the instrument cluster. Unclip the ignition trim and remove. Unclip the climate control / radio trim bezel and remove. Depress the spring clips on each side of the factory head unit and remove.

## PONTIAC Sunfire 2000-2005

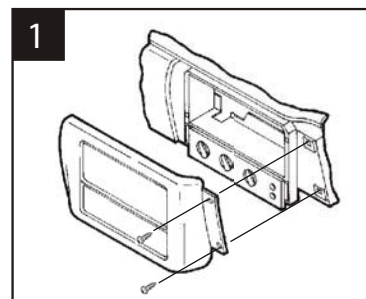

Disconnect the negative battery terminal to prevent an accidental short circuit. Open the glove box and remove (2) Phillips screws exposed on the right edge of the radio trim bezel. Unclip the bezel and remove. Remove (2) 7mm hex-head screws securing the factory head unit and disconnect the wiring. Skip to the Installation Instructions for ALL VEHICLES on Page #3.