



Installation instructions for part 99-7431

## Nissan Multi Kit 1993-2004 99-7431

### KIT FEATURES

- DIN radio provision with pocket
- ISO DIN radio provision with pocket
- ISO DDIN radio provision

### KIT COMPONENTS

- A) ISO DDIN trim plate • B) ISO DDIN brackets • C) Radio housing • D) ISO DIN trim plate • E) Bracket set #1
- F) Bracket set #2 • G) Bracket set #3 • H) ISO DIN brackets • I) (4) #8 x 1/2 Phillips screws

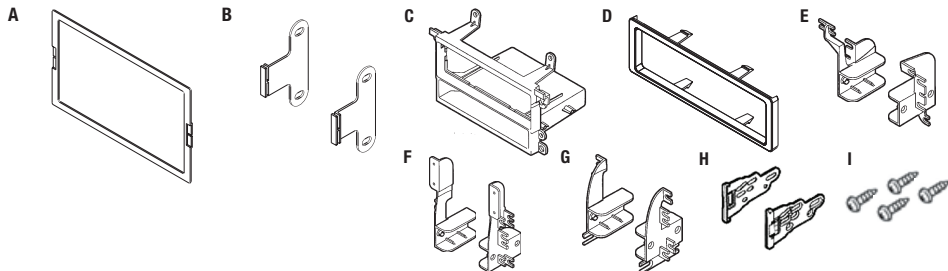

### APPLICATIONS

See application list inside cover

### WIRING & ANTENNA CONNECTIONS (sold separately)

#### Wiring Harness:

- Please visit [metraonline.com](http://metraonline.com) for harness options

#### Antenna Adapter:

- Please visit [metraonline.com](http://metraonline.com) for antenna options

### TOOLS REQUIRED

- Panel removal tool • Cutting tool
- Phillips screwdriver • Socket wrench

**CAUTION!** All accessories, switches, climate controls panels, and especially air bag indicator lights must be connected before cycling the ignition. Also, do not remove the factory radio with the key in the on position, or while the vehicle is running.

## Applications

### **INFINITI**

I-30	1996-1999
QX4	1997-2000

### **MERCURY**

Villager	1993-2002
----------	-----------

### **NISSAN**

200SX	1995-1998
240SX	1995-1998
Altima	1998-2001
Frontier	1998-2004

### **NISSAN (Cont'd)**

Maxima	1995-1999
Maxima (without wrap around radio)	2000-2003
Pathfinder	1996-2000
Pathfinder (without NAV)	2001-2002
Pathfinder SE	2003-2004
Quest	1993-2003
Sentra	1995-1999
Xterra	2000-2004

## Table of Contents

<b>Dash Disassembly</b> .....	3-13	<b>Nissan (Cont'd)</b>	
<b>Infiniti</b>		- Pathfinder (without NAV)	
- I-30 1996-1999 .....	3	2001-2002 .....	13
- QX4 1997-2000 .....	3	- Pathfinder SE 2003-2004 .....	13
<b>Mercury</b>		- Quest 1993-1995 .....	4
- Villager 1993-1995 .....	4	- Quest 1996-1998 .....	5
- Villager 1996-1998 .....	5	- Quest 1999-2003 .....	6
- Villager 1999-2002 .....	6	- Sentra 1995-1999 .....	7
<b>Nissan</b>		- Xterra 2000-2001 .....	10
- 200SX 1995-1998 .....	7	- Xterra 2002-2004 .....	11
- 240SX 1995-1998 .....	8	<b>Kit Preparation</b> .....	14
- Altima 1998-2001 .....	9	<b>Kit Assembly</b>	
- Frontier 1998-2001 .....	10	- DIN radio provision with pocket... 15	
- Frontier 2002-2004 .....	11	- ISO DIN radio provision with pocket. 15	
- Maxima 1995-1999 .....	3	- ISO DDIN radio provision .....	15
- Maxima (without wrap around radio) 2000-2003 .....	12	<b>Final Assembly</b> .....	16
- Pathfinder 1996-2000 .....	3		

## Dash Disassembly

### Infiniti I-30 1996-1999

### Nissan Maxima 1995-1999

1. Unclip the gear shifter trim bezel.
2. Remove (1) screw to the left of the ashtray, then unclip and remove the ashtray assembly.
3. Remove (2) screws exposed.
4. Unclip the clock/vent assembly and remove (2) screws exposed.
5. Remove the climate/radio assembly.
6. Remove the screws securing the climate/radio to the trim bezel.
7. Remove (8) screws securing the radio or radio/pocket to the assembly and then remove.
8. Using a hammer, flatten the protruding screw holes on the factory mounting brackets.
9. **If installing a single DIN aftermarket radio:** Cut and remove all mounting tabs on the *radio housing* EXCEPT tabs "A". (Figure B)

**Note:** The tabs can be identified by the stamped letter on each tab.

Continue to kit assembly

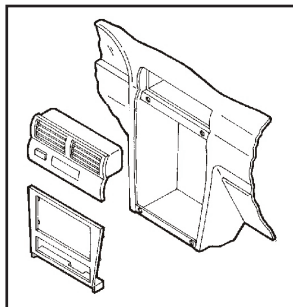

(Figure A)

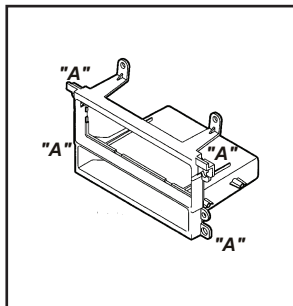

(Figure B)

### Infinity QX4 1997-2000

### Nissan Pathfinder 1996-2000

1. Remove (2) screws from the base of the radio trim bezel. (Figure A)
2. Unclip the bottom edge of the radio trim bezel and disconnect the hazard light, defroster, wiper and cigarette lighter wiring and remove the radio trim bezel. (Figure A)
3. Remove (4) screws securing the factory radio and disconnect the wiring.
4. **If installing a double DIN aftermarket radio:** Remove the factory brackets from the radio. Retain the brackets for use during kit assembly.
5. **If installing a single DIN aftermarket radio:** Cut Bracket Set #2 along the scored lines removing the SHADED portions of the brackets. (Figure B)
6. **If installing a single DIN aftermarket radio:** Cut and remove all mounting tabs EXCEPT tabs "A" and "C". (The tabs can be identified by the stamped letter by each tab). (Figure B)

*If installing a single DIN aftermarket radio, continue to Kit Preparation.*

*If installing a double DIN aftermarket radio, continue to Kit Assembly.*

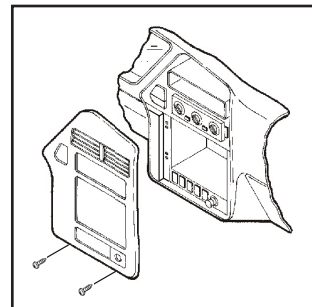

(Figure A)

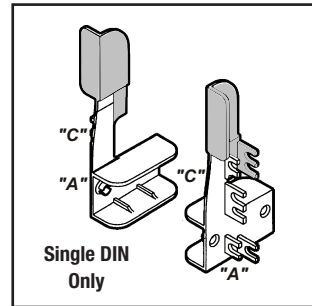

(Figure B)

## Dash Disassembly

### Mercury Villager 1993-1995

### Nissan Quest 1993-1995

1. Remove (1) screw above the climate controls and then unclip the radio trim bezel and remove. (Figure A)
2. Remove (4) Phillips screws securing the factory radio housing and remove the housing and disconnect the wiring.
3. Remove (8) Phillips screws securing the factory radio to the factory radio housing and remove the radio.
4. **If installing a double DIN aftermarket radio:**  
Remove the factory brackets from the radio.  
Retain the brackets for use during kit assembly.
5. **If installing a single DIN aftermarket radio:**  
Cut and remove all mounting tabs on Bracket Set #2 EXCEPT tabs "D". (The tabs can be identified by the stamped letter by each tab). (Figure B)

*If installing a single DIN aftermarket radio, continue to Kit Preparation.*

*If installing a double DIN aftermarket radio, continue to Kit Assembly.*

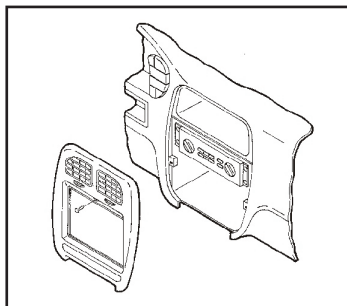

(Figure A)

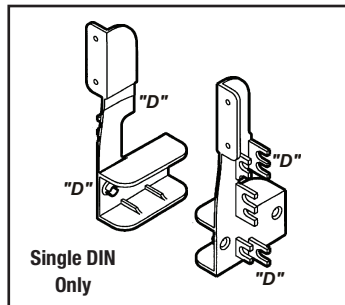

(Figure B)

## Dash Disassembly

### Mercury Villager 1996-1998

### Nissan Quest 1996-1998

1. Remove (4) plastic screws from the base of the storage compartment, then pop out the (4) anchor clips securing the screws and remove the compartment. (Figure A)
2. Remove (2) Phillips screws from the base of the radio trim bezel and then remove (2) Phillips screws above the radio opening.
3. Remove the ashtray and then pull up and out on the radio trim bezel and remove the bezel.
4. Remove (4) Phillips screws securing the factory radio housing and remove the housing and disconnect the wiring.
5. Remove (2) Phillips screws securing the factory radio to the housing and remove the radio.
6. **If installing a double DIN aftermarket radio:** Remove the factory brackets from the radio. Retain the brackets for use during kit assembly.
7. **If installing a single DIN aftermarket radio:** Cut and remove all mounting tabs on Bracket Set #2 EXCEPT tabs "D". (The tabs can be identified by the stamped letter by each tab). (Figure B)

*If installing a single DIN aftermarket radio, continue to Kit Preparation.*

*If installing a double DIN aftermarket radio, continue to Kit Assembly.*

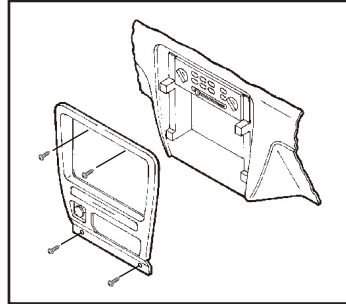

(Figure A)

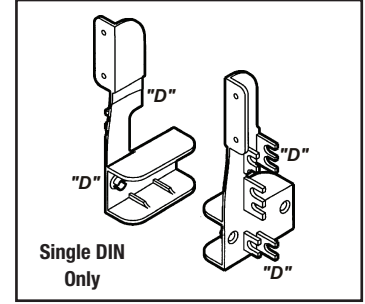

(Figure B)

## Dash Disassembly

### Mercury Villager 1999-2002

### Nissan Quest 1999-2003

1. Open the ashtray/cupholder assembly, depress the retaining clips on each side and remove the assembly. (Figure A)
2. Remove (2) Phillips screws from each side of the ashtray/cupholder assembly.
3. Remove (4) plastic rivets from the lower pocket and slide the pocket back.

**Note:** *It is NOT necessary to remove the pocket. Unclip the dash trim bezel and remove.*

4. Remove (4) Phillips screws securing the factory radio and disconnect the wiring.
5. **If installing a double DIN aftermarket radio:** Remove the factory brackets from the radio. Retain the brackets for use during kit assembly.
6. **If installing a single DIN aftermarket radio:** Cut Bracket Set #1 along the scored lines removing the SHADED portions of the brackets. (Figure B)
7. **If installing a single DIN aftermarket radio:** Cut and remove all mounting tabs EXCEPT tabs "A". (The tabs can be identified by the stamped letter by each tab). (Figure B)

*If installing a single DIN aftermarket radio, continue to Kit Preparation.*

*If installing a double DIN aftermarket radio, continue to Kit Assembly.*

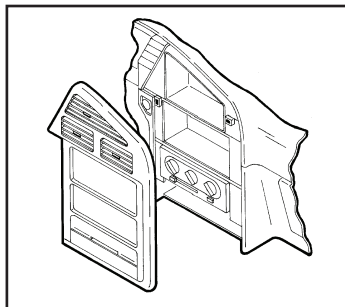

(Figure A)

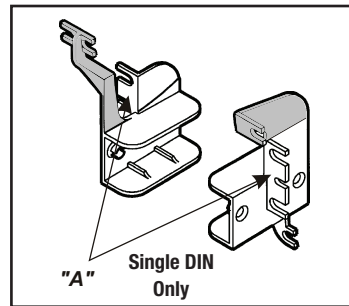

(Figure B)

## Dash Disassembly

**Nissan 200SX 1995-1998**

**Nissan Sentra 1995-1999**

1. Unclip the dummy plate from the center of the switch panel (above the radio opening), then unclip the radio trim bezel and remove. (Figure A)
2. Remove (4) Phillips screws securing the factory radio and disconnect the wiring.
3. Remove (2) Phillips screws securing the factory cupholder and remove
4. **If installing a double DIN aftermarket radio:**  
Remove the factory brackets from the radio. Retain the brackets for use during kit assembly.
5. **If installing a single DIN aftermarket radio:**  
Cut Bracket Set #3 along the scored lines removing the SHADED portions of the brackets. (Figure B)
6. **If installing a single DIN aftermarket radio:**  
Cut and remove all mounting tabs EXCEPT tabs "A". (The tabs can be identified by the stamped letter by each tab). (Figure B)

*If installing a single DIN aftermarket radio, continue to Kit Preparation.*

*If installing a double DIN aftermarket radio, continue to Kit Assembly.*

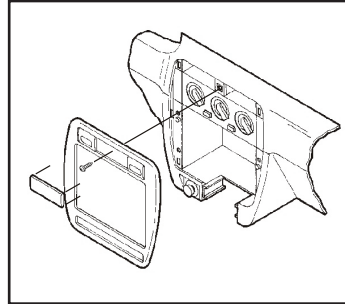

(Figure A)

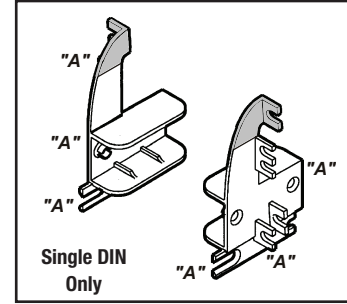

(Figure B)

## Dash Disassembly

### Nissan 240SX 1995-1998

1. Unclip the gear shifter trim bezel.
2. Remove (1) screw to the left of the ashtray, then unclip and remove the ashtray assembly.
3. Remove (2) screws exposed.
4. Unclip the clock/vent assembly and remove (2) screws exposed.
5. Remove the climate/radio assembly.
6. Remove the screws securing the climate/radio to the trim bezel.
7. Remove (8) screws securing the radio or radio/pocket to the assembly and then remove.
8. Using a hammer, flatten the protruding screw holes on the factory mounting brackets.
9. **If installing a single DIN aftermarket radio:** Cut and remove all mounting tabs on the *radio housing* EXCEPT tabs "B" and "C". (Figure B)

**Note:** *The tabs can be identified by the stamped letter on each tab.*

*Continue to kit assembly*

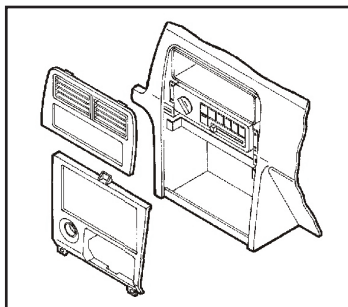

(Figure A)

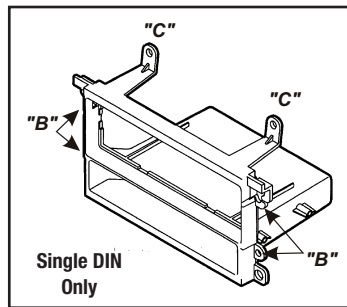

(Figure B)



## Dash Disassembly

### Nissan Altima 1998-2001

1. Unclip the gear shifter trim bezel and remove (2) Phillips screws exposed. (Figure A)
2. Remove (2) Phillips screws above the radio opening and unclip the radio trim bezel. (Figure A)
3. Remove (4) Phillips screws from the factory radio and disconnect the wiring.
4. **If installing a double DIN aftermarket radio:** Remove the factory brackets from the radio. Retain the brackets for use during kit assembly.
5. **If installing a single DIN aftermarket radio:** Cut Bracket Set #3 along the scored lines removing the SHADED portions of the brackets. (Figure B)
6. **If installing a single DIN aftermarket radio:** Cut and remove all mounting tabs EXCEPT tabs "B". (The tabs can be identified by the stamped letter by each tab). (Figure B)

*If installing a single DIN aftermarket radio, continue to Kit Preparation.*

*If installing a double DIN aftermarket radio, continue to Kit Assembly.*

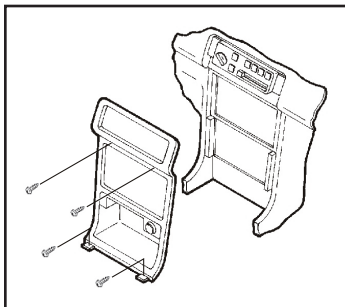

(Figure A)

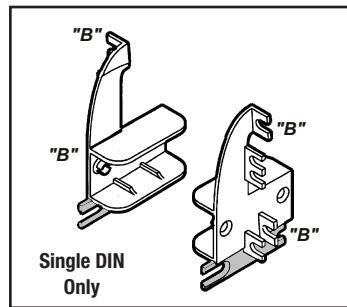

(Figure B)

## Dash Disassembly

### Nissan Frontier 1998-2001

### Nissan Xterra 2000-2001

1. Remove the ashtray and (2) Phillips screws exposed in the ashtray cavity and then unclip the radio trim bezel and remove. (Figure A)
2. Remove (4) Phillips screws securing the factory radio and disconnect the wiring.
3. **If installing a double DIN aftermarket radio:** Remove the factory brackets from the radio. Retain the brackets for use during kit assembly.
4. **If installing a single DIN aftermarket radio:** Cut Bracket Set #2 along the scored lines removing the SHADED portions of the brackets. (Figure B)
5. **If installing a single DIN aftermarket radio:** Cut and remove all mounting tabs EXCEPT tabs "A" and "B". (The tabs can be identified by the stamped letter by each tab). (Figure B)

*If installing a single DIN aftermarket radio, continue to Kit Preparation.*

*If installing a double DIN aftermarket radio, continue to Kit Assembly.*

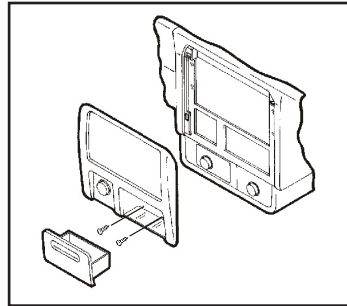

(Figure A)

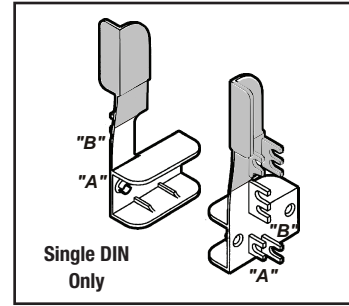

(Figure B)

## Dash Disassembly

### Nissan Frontier 2002-2004

### Nissan Xterra 2002-2004

1. Unclip the gear shifter trim bezel and remove.
2. Remove (2) Phillips screws exposed in the shifter cavity.
3. Remove (2) Phillips screws under the climate control cluster and then unclip the radio trim bezel and remove. (Figure A)
4. Remove (4) Phillips screws securing the factory radio and disconnect the wiring.

**CAUTION: Do not cycle the key when removing a dash with passenger airbag on/off switch).**

5. **If installing a single DIN aftermarket radio:** Cut Bracket Set #2 along the scored lines removing the SHADED portions of the brackets. (Figure B)
6. **If installing a single DIN aftermarket radio:** Cut Bracket Set #2 along the scored lines removing the SHADED portions of the brackets. (Figure B)
7. **If installing a single DIN aftermarket radio:** Cut and remove all mounting tabs EXCEPT tabs "A" and "B". (The tabs can be identified by the stamped letter by each tab). (Figure B)

*If installing a single DIN aftermarket radio, continue to Kit Preparation.*

*If installing a double DIN aftermarket radio, continue to Kit Assembly.*

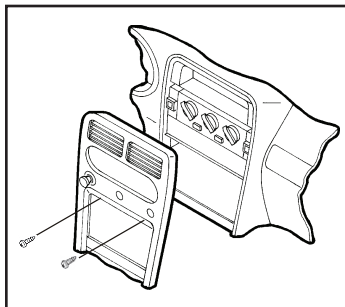

(Figure A)

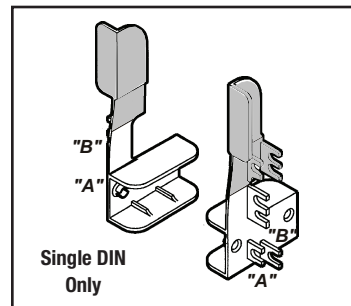

(Figure B)

## Dash Disassembly

### Nissan Maxima (without wrap around radio) 2000-2003

1. Unclip the vent/radio trim bezel assembly and remove. (Figure A)
2. Remove the ashtray insert, and then (1) Phillips screw exposed.
3. Unclip the ashtray/shifter trim bezel assembly and then remove. (Figure A)
4. Remove (2) Phillips screws above the factory radio, and (2) Phillips screws below the climate control panel. (Figure A)
5. Remove the radio/climate-control-panel assembly and disconnect the wiring.
6. **If installing a double DIN aftermarket radio:**  
Remove the factory brackets from the radio. Retain the brackets for use during kit assembly.
7. **If installing a single DIN aftermarket radio:**  
Cut and remove all mounting tabs on the *radio housing*. (Figure B)

*Continue to kit assembly*

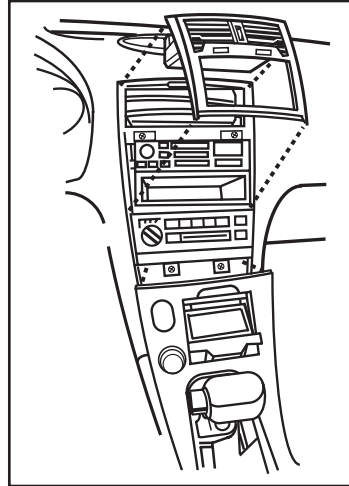

(Figure A)

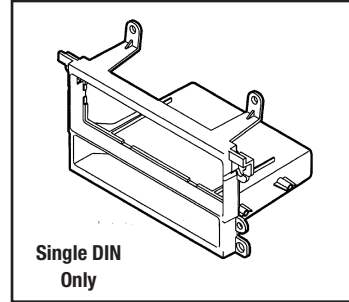

(Figure B)

## Dash Disassembly

### Nissan Pathfinder (without NAV) 2001-2002

### Nissan Pathfinder SE 2003-2004

1. Using a panel removal tool, pry out on the top of the vent assembly (w/ clock) and remove. (Figure A)
2. Remove (2) Phillips screws from the top of the radio trim bezel and remove. (Figure B)
3. Remove (4) Phillips screws securing the factory radio and disconnect the wiring.
4. **If installing a double DIN aftermarket radio:** Remove the factory brackets from the radio. Retain the brackets for use during kit assembly.
5. **If installing a single DIN aftermarket radio:** Cut and remove all mounting tabs from Bracket Set #1 EXCEPT tabs "B". (The tabs can be identified by the stamped letter by each tab). (Figure C)

*If installing a single DIN aftermarket radio, continue to Kit Preparation.*

*If installing a double DIN aftermarket radio, continue to Kit Assembly.*

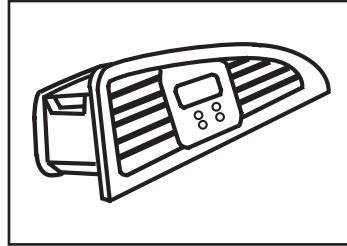

(Figure A)

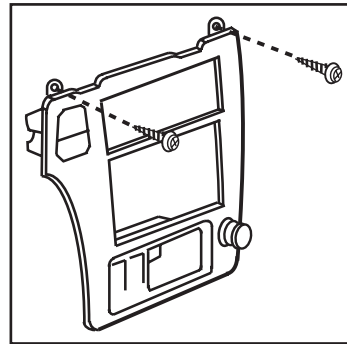

(Figure B)

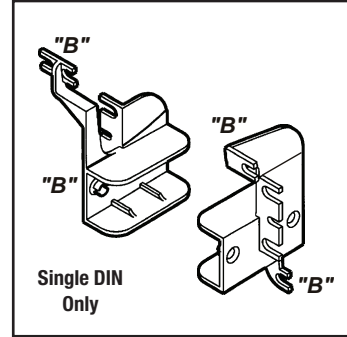

(Figure C)

## Kit Preparation

### Altima, Frontier, Pathfinder, Quest, Villager, Xterra:

1. Cut and remove all the mounting tabs from the *radio housing*.
2. Secure the appropriate bracket to the *radio housing* using the (4) Phillips flat head screws provided. (Figure A)

*Continue to kit assembly*

### 200SX, Sentra:

1. Cut and remove all the mounting tabs from the *radio housing*.
2. Secure the right bracket to the *radio housing* using the (2) Phillips flat head screws provided. (Figure A)
3. Secure the right bracket to the factory cupholder using the (1) factory screw and (1) locating pin. (Figure A)
4. Secure the left bracket to the *radio housing* using the (2) Phillips flat head screws provided. (Figure A)
5. Secure the left bracket to the factory cupholder using the (1) factory screw and (1) locating pin. (Figure A)

*Continue to kit assembly*

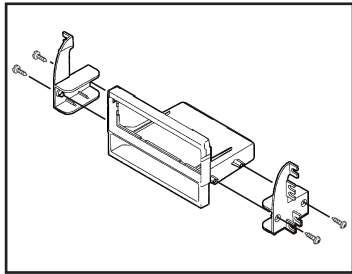

(Figure A)

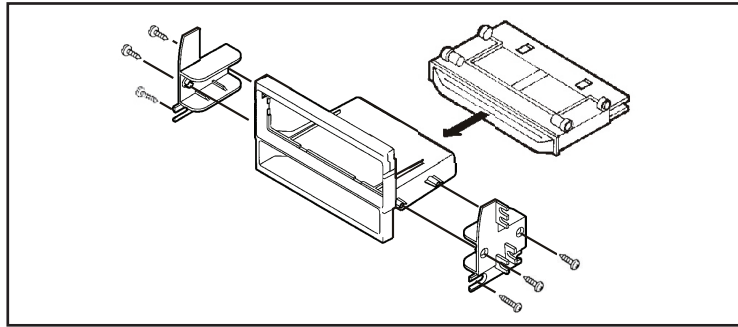

(Figure A)

## Kit Assembly

### DIN radio provision with pocket

1. Remove the metal DIN sleeve from the aftermarket radio.
2. Slide the sleeve into the *radio housing* and secure by bending the metal locking tabs down. (Figure A)
3. Slide the radio back into the sleeve until it clicks in. (Figure A)

*Continue to final assembly*

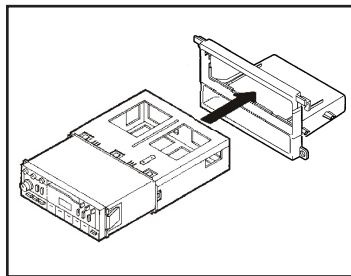

(Figure A)

### ISO DIN radio provision with pocket

1. Remove the metal DIN sleeve and trim ring from the aftermarket radio.
2. Secure the *ISO DIN brackets* to the radio using the screws supplied with the radio. (Figure A)
3. Slide the radio/bracket assembly into the *radio housing* until the side clips engage. (Figure A)
4. Attach the *ISO DIN trim ring* over the radio. (Figure A)

*Continue to final assembly*

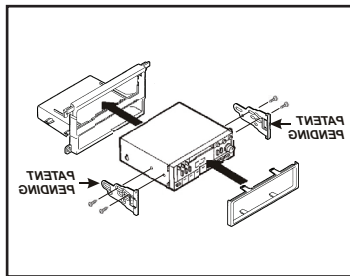

(Figure A)

### ISO DDIN radio provision

1. Slide the *ISO DDIN brackets* into the *ISO DDIN trim plate* aligning the holes in the trim plate to the clips on the bracket. (Figure A)
2. Attach the factory mounting brackets and the *ISO DDIN trim plate/bracket* assembly to the radio with the screws supplied with the radio. (Figure B)
3. Locate the factory wiring harness and antenna connector in the dash, and complete all necessary connections to the radio. Metra recommends using the proper mating adapter from Metra and/or AXCESS. Test the radio for proper operation.
4. Reassemble the dash in reverse order of disassembly.

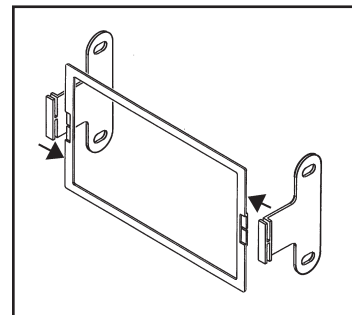

(Figure A)

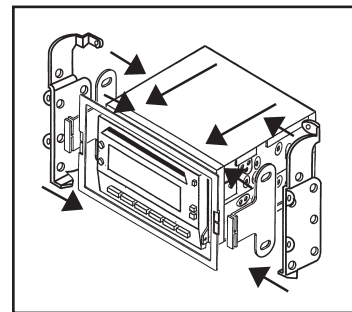

(Figure B)



## Installation instructions for part 99-7431



### Final Assembly

1. Locate the factory wiring harness and antenna connector in the dash and complete all necessary connections to the radio. Metra recommends using the proper mating adapter from Metra and/or AXCESS. Test the radio for proper operation.

#### For the Nissan Maxima 1995-1999 / Infiniti I-30 1996-1999:

1. Mount the completed assembly to the factory trim bezel and factory bracket assembly using the factory screws. (Figure A)
2. Mount to the sub-dash using the factory screws, and then reassemble the dash in reverse order of disassembly.

#### For the Nissan Maxima (without wrap around radio) 2000-2003:

1. Mount the completed assembly to the factory bracket assembly using the (4) Phillips flat-head screws supplied.
2. Mount to the sub-dash using the factory screws, and then reassemble the dash in reverse order of disassembly.

#### For the Nissan 240SX 1995-1998:

1. Mount the completed assembly to the factory trim bezel (via tabs "B") using the factory screws.
2. Mount to the sub-dash (via tabs "C") using the factory screws, and then reassemble the dash in reverse order of disassembly.

#### For all other applications:

1. Reassemble the dash in reverse order of disassembly.

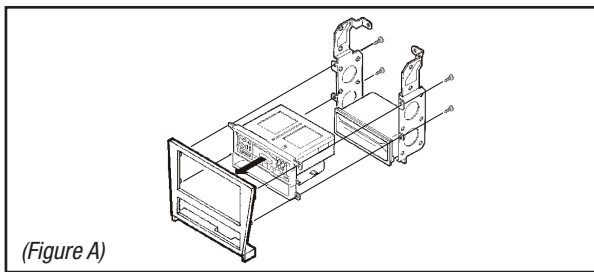

(Figure A)

### IMPORTANT

If you are having difficulties with the installation of this product, please call our Tech Support line at **1-800-253-TECH**. Before doing so, look over the instructions a second time, and make sure the installation was performed exactly as the instructions are stated. Please have the vehicle apart and ready to perform troubleshooting steps before calling.



#### KNOWLEDGE IS POWER

Enhance your installation and fabrication skills by enrolling in the most recognized and respected mobile electronics school in our industry. Log onto [www.installerinstitute.com](http://www.installerinstitute.com) or call 800-354-6782 for more information and take steps toward a better tomorrow.



**Metra recommends MECP certified technicians**