

KIT FEATURES

- ▶ Shaft and DIN unit provisions

KIT COMPONENTS

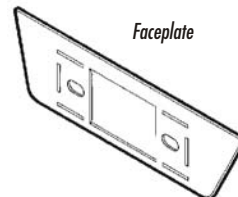

TOOLS REQUIRED



Phillips screwdriver



Cutting tool



Scribing tool

99-7471

INSTALLATION INSTRUCTIONS

APPLICATIONS

CAR	PAGE
NISSAN	
280ZX 1979-83.....	1-2



ALL VEHICLES

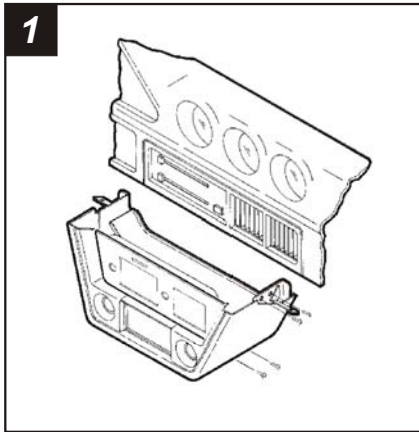

Disconnect the negative battery terminal to prevent an accidental short circuit. Remove (2) screws from each lower inspection panel and remove the panels. Remove (1) screw from each console side cover and remove the covers. Remove (8) 10mm hex-head bolts securing the console to the sub-dash. Pull the console out and disconnect the wiring. Remove (4) screws securing the top of the factory radio and (5) screws securing the bottom.

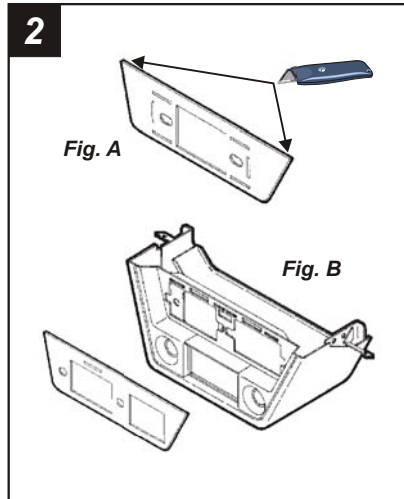

MODELS EQUIPPED WITH A METALLIC RADIO TRIM BEZEL: Skip to step #3.

MODELS EQUIPPED WITH A BLACK RADIO TRIM BEZEL WITH A 2-SHAFT OPENING: Using the scored lines as a guide, cut and remove the side portions of the **Faceplate**. (see Fig. A). Remove the radio trim bezel. (see Fig. B).

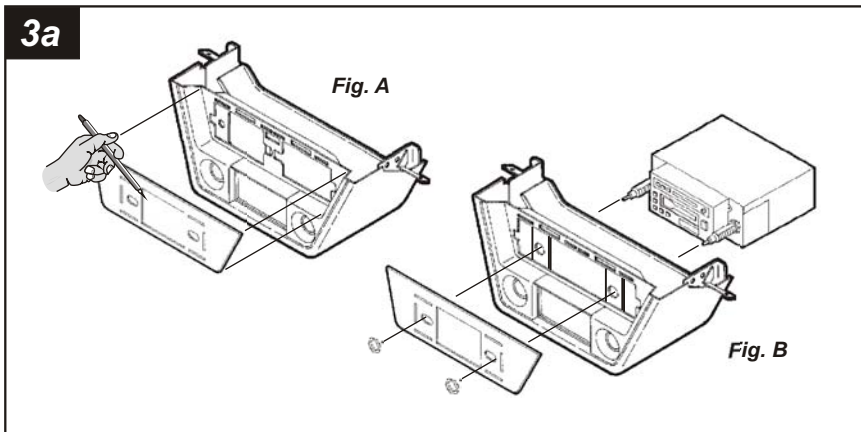

2-SHAFT HEAD UNITS: Using the **Faceplate** as a template, scribe the radio opening onto the face of the console. (see Fig. A). Cut along the scribed lines until the nose hole and shaft holes are formed. Place the Faceplate over the radio opening in the console. Place the **Shaft Tabs** against the back of the radio opening and align the holes with the holes in the Faceplate. Slide the aftermarket head unit through the kit and secure with shaft nuts. (see Fig. B).

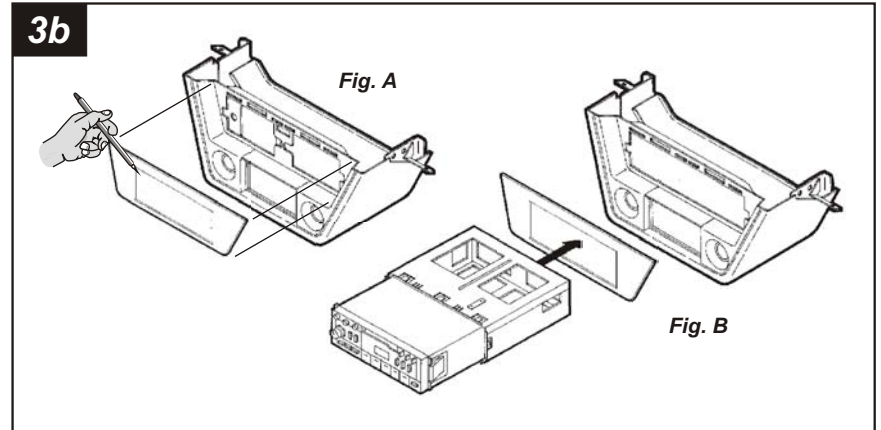

DIN HEAD UNITS: Using the converted **Faceplate** as a template, scribe the radio opening onto the face of the console. (see Fig. A). Cut along the scribed lines until the DIN hole is formed. Place the Faceplate over the radio opening in the console. Slide the DIN cage through the radio opening and secure by bending the metal locking tabs down. Slide the aftermarket head unit into the cage until secure. (see Fig. B).

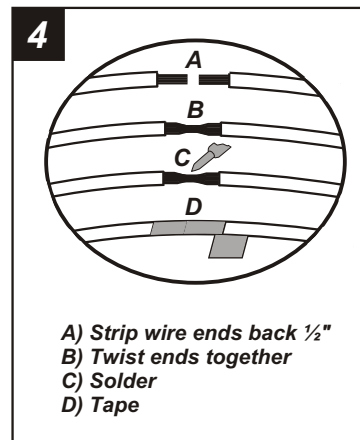

Locate the factory wiring harness in the dash. Metra recommends using the proper mating adaptor and making connections as shown. (Isolate and individually tape off the ends of any unused wires to prevent electrical short circuit).

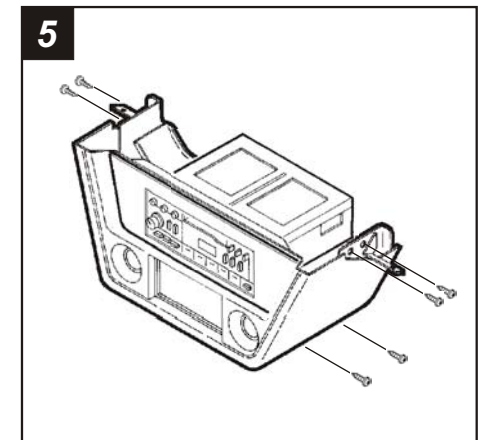

Re-connect the battery terminal to prevent an accidental short circuit. Mount the console assembly to the sub-dash with (8) screws previously removed in step #1.