



INSTALLATION INSTRUCTIONS FOR PART 99-7815B

Acura TL 2004-2008 99-7815B

KIT FEATURES

- ISO DIN radio provision with pocket
- *Painted matte black*

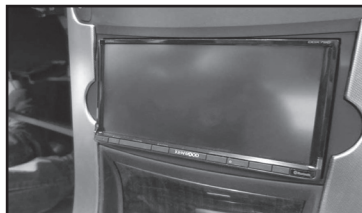

KIT COMPONENTS

- A) Radio trim panel • B) Radio brackets • C) Pocket • D) (4) #8 x 3/8" Phillips screws

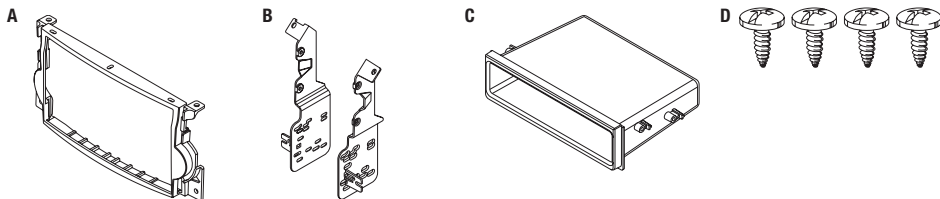

WIRING & ANTENNA CONNECTIONS (sold separately)

Wiring Harness: 70-1721 Antenna Adapter: 04-06 not required • 07-08 40-HD10
Steering wheel control interface: ASWC-1

Table of Contents

Dash Disassembly	2-5
Kit Preparation	6
Kit Assembly	7

TOOLS REQUIRED

- Panel removal tool • Phillips screwdriver

CAUTION! All accessories, switches, climate controls panels, and especially air bag indicator lights must be connected before cycling the ignition. Also, do not remove the factory radio with the key in the on position, or while the vehicle is running.

REV. 2/15/2017 INST99-7815B

Dash Disassembly

1. Unclip the trim panels along the sides of the dash, down to the console. (Figure A)
2. Remove (9) Phillips screws along the top of the console, and (2) Phillips screws inside the console's rear storage compartment. (Figure B)
3. Slide the console back.

Continued on next page

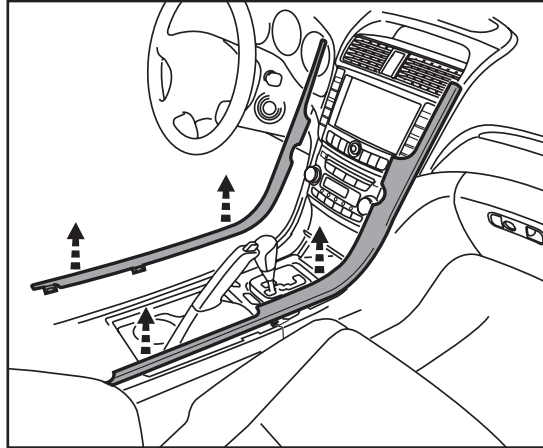

(Figure A)

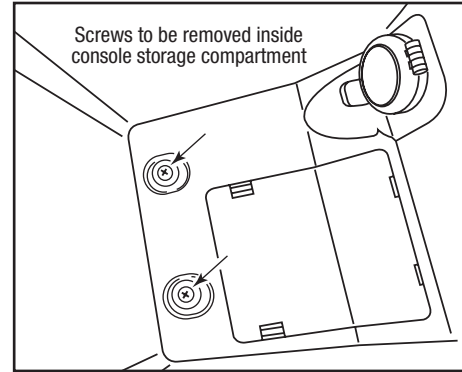

(Figure B)

Dash Disassembly *(cont.)*

4. Drop the glove box door, remove (2) Phillips screws, and (2) push pins to drop the glove box assembly. (Figure C)
5. Remove (1) push pin and remove the driver's knee panel. (Figure D)
6. Remove (1) Phillips screw from each side console panel, and unclip to remove the panels. (Figure E)

Continued on the next page

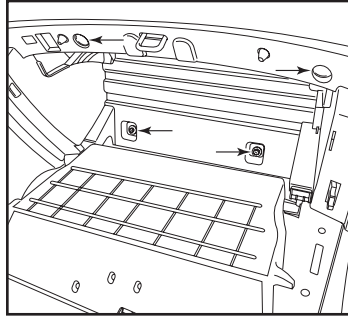

(Figure C)

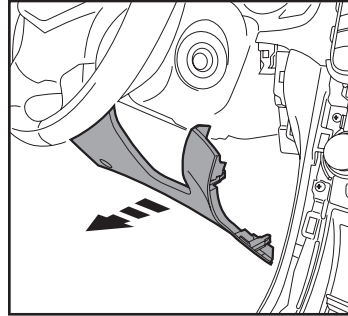

(Figure D)

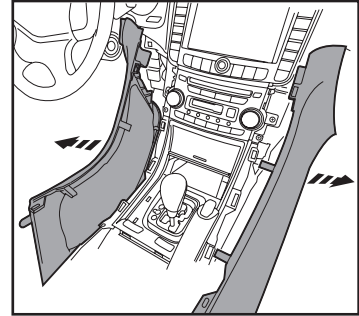

(Figure E)

Dash Disassembly (cont.)

7. Unclip and remove the shift lever trim panels, then remove (2) Phillips screws to remove the lower console storage pocket. (Figure F)
8. Unclip, unplug, and remove the vent assembly from above the radio. (Figure G)

Continued on the next page

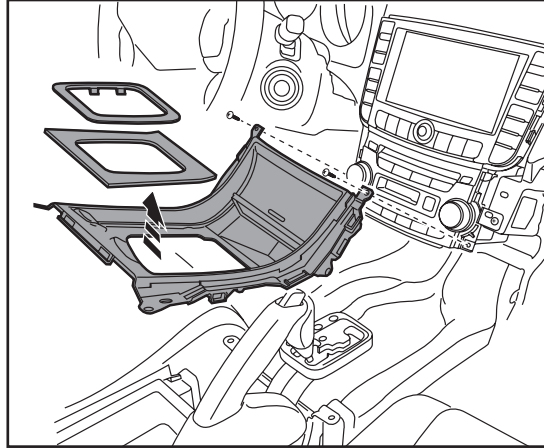

(Figure F)

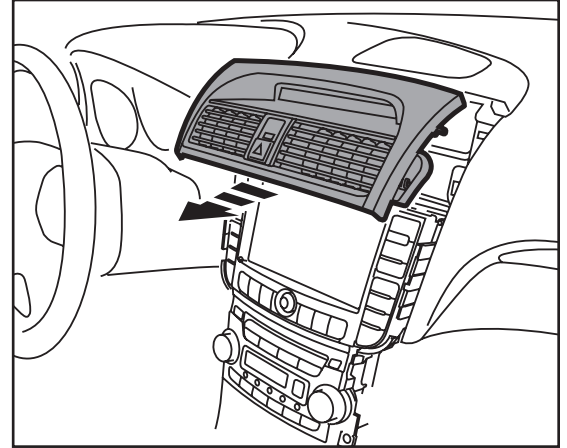

(Figure G)

Dash Disassembly (cont.)

9. Remove (4) Phillips screws to remove the factory radio assembly. (Figures H, I)

Continue to Kit Preparation

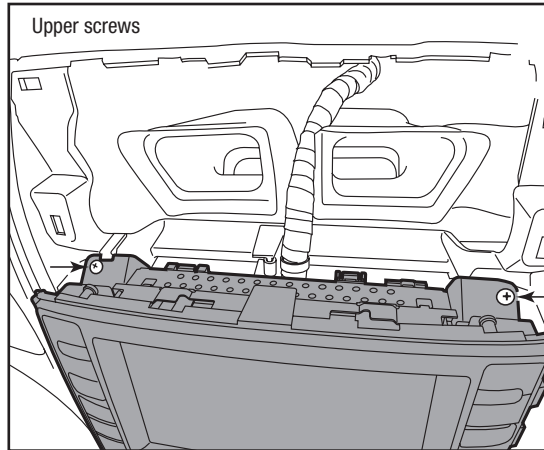

(Figure H)

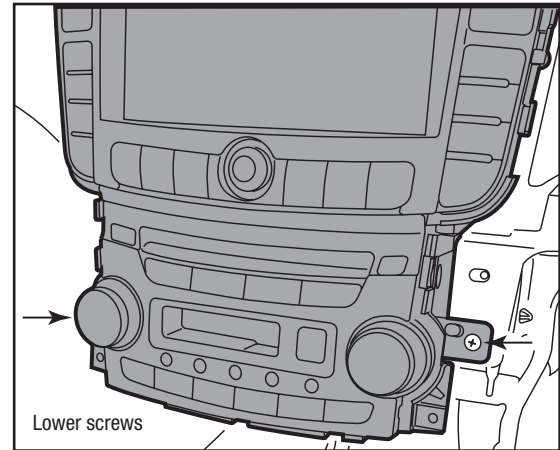

(Figure I)

Kit Preparation

1. Remove the factory radio brackets to release the factory climate controls/screen for kit assembly. (Figure A)
2. Remove the (2) factory speed clips from the bottom mounting tabs of the radio, and slide them onto the bottom mounting tabs of the 99-7815B radio trim panel. (Figure B)

Continue to Kit Assembly

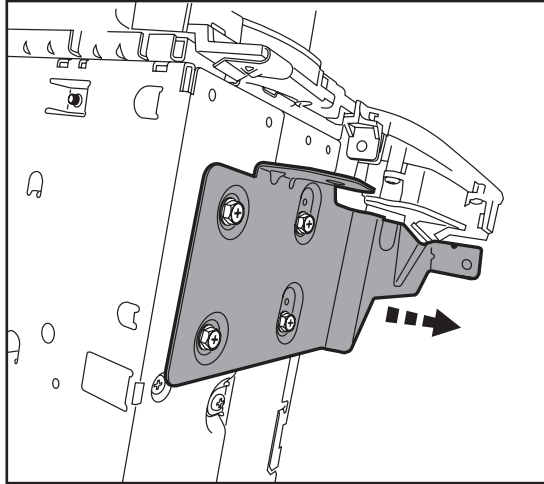

(Figure A)

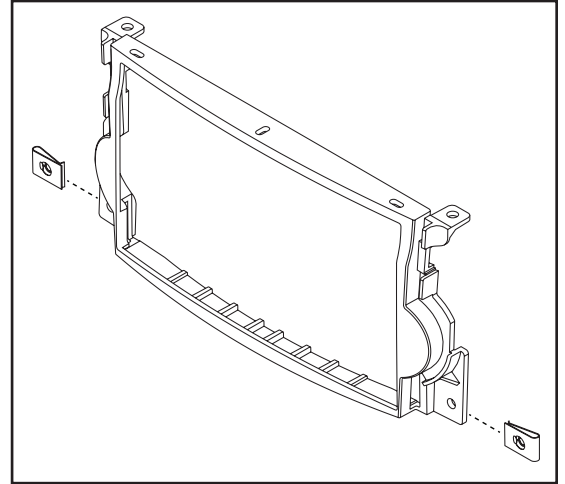

(Figure B)

Kit Assembly

ISO DIN radio provision with pocket

1. Attach the *radio brackets* to the factory climate controls using the factory hardware. (Figure A)
2. Attach the *radio trim panel* to the bottom of the factory climate controls using the factory hardware. (Figure B)
3. Attach the *pocket* to the bracket/radio trim panel assembly using the (4) supplied #8 x 3/8" Phillips screws. (Figure C)
4. Remove the metal DIN sleeve and trim ring from the aftermarket radio.
5. Slide the radio into the bracket/panel assembly and secure it using the screws supplied with the radio. (Figure D)

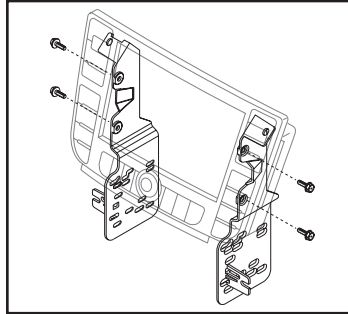

(Figure A)

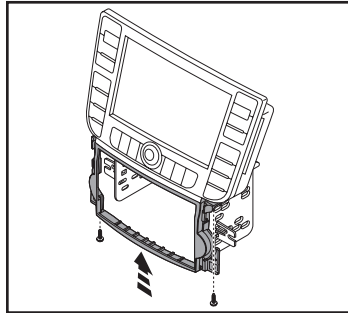

(Figure B)

6. Locate the factory wiring harness and antenna connector in the dash, and complete all necessary connections to the radio and climate controls. Metra recommends using the proper mating adapter from Metra and/or AXCESS. Test the radio and climate controls for proper operation.
7. Reassemble the dash in reverse order of disassembly.

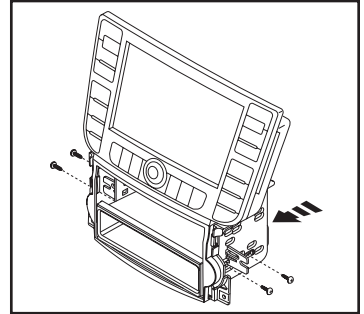

(Figure C)

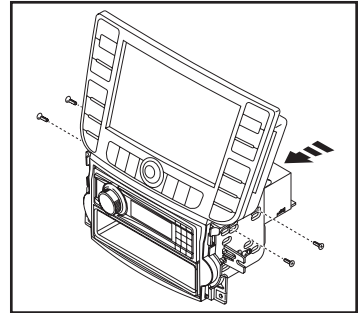

(Figure D)



INSTALLATION INSTRUCTIONS FOR PART 99-7815B



IMPORTANT

If you are having difficulties with the installation of this product, please call our Tech Support line at 1-800-253-TECH. Before doing so, look over the instructions a second time, and make sure the installation was performed exactly as the instructions are stated. Please have the vehicle apart and ready to perform troubleshooting steps before calling.

REV. 2/15/2017 INST99-7815B



KNOWLEDGE IS POWER

Enhance your installation and fabrication skills by enrolling in the most recognized and respected mobile electronics school in our industry. Log onto www.installerinstitute.com or call 800-354-6782 for more information and take steps toward a better tomorrow.



Metra recommends MECP certified technicians