



Installation instructions for 99-7867

U.S. Patent # D481,707

Acura RSX 2002-2006 99-7867

KIT FEATURES

- DIN radio provision with pocket
- ISO DIN radio provision with pocket



KIT COMPONENTS

- A) Radio housing
- B) ISO Trim plate
- C) ISO Brackets
- D) (4) #8 x 3/8" Phillips screws

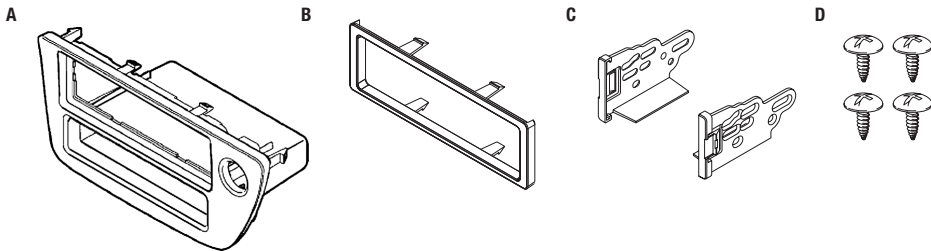

WIRING & ANTENNA CONNECTIONS (sold separately)

Wiring Harness:

- 70-1721
- 70-1725

Antenna Adapter:

- Not required

TOOLS REQUIRED

- Panel removal tool
- Phillips screwdriver

CAUTION: Metra recommends disconnecting the negative battery terminal before beginning any installation. All accessories, switches, and especially air bag indicator lights must be plugged in before reconnecting the battery or cycling the ignition.

NOTE: Refer to the instructions included with the aftermarket radio.

REV 11/17/2017 INST99-7867

Table of Contents

Dash Disassembly

– Acura RSX 2002-20062

Kit Preparation3

Kit Assembly

– DIN radio provision with pocket.....3

– ISO DIN radio provision with pocket.....4

Acura RSX 2002-2006

1. Unclip the power outlet panel and remove (2) Phillips screws exposed facing up. (Figure A, "A")
2. Unclip the radio trim panel assembly (including the radio and the hazard switch) then unplug and remove the assembly. (Figure A)
3. Remove (4) Phillips screws securing the factory radio to the bracket assembly and remove the unit. (Figure A, "B")
4. If a factory pocket is present, remove (4) Phillips screws securing the pocket to the bracket assembly and remove.
5. Remove (4) Phillips screws securing the bracket assembly to the back of the radio trim bezel and remove the bezel. (Retain the bracket assembly and screws to be reinstalled into the double DIN trim plate during kit assembly. Screws have been provided in the event the factory screws are not present.) (Figure B)
6. Remove (2) Phillips screws securing the hazard switch to the back of the radio trim panel and remove the switch. (Retain the switch and screws to be reinstalled into the double DIN trim plate during kit assembly.) (Figure C)

Continue to kit preparation

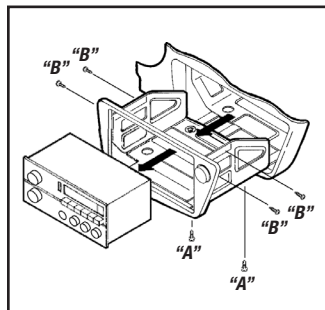

(Figure A)

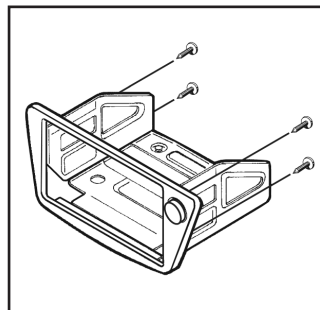

(Figure B)

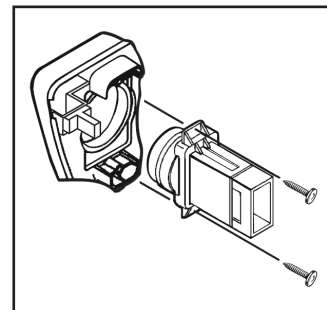

(Figure C)

Acura RSX 2002-2006

1. Mount the hazard switch to the back of the radio housing with (2) Phillips screws previously removed in Step 7 of the disassembly. (Figure A)
2. Mount the factory bracket assembly to the back of the radio housing with (4) Phillip screws previously removed in Step 6 of the disassembly. (Figure B)

Continue to kit assembly

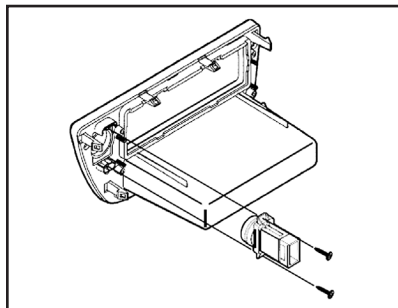

(Figure A)

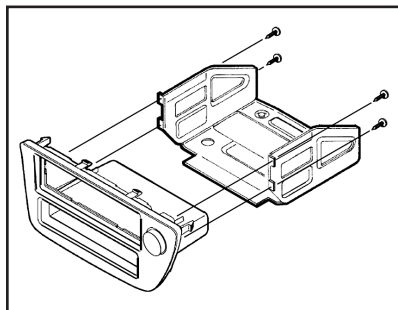

(Figure B)

DIN radio provision with pocket

1. Slide the DIN cage into the radio housing and secure by bending the metal locking tabs outward. (Figure A)
2. Slide the aftermarket radio into the cage until it snaps into place. (Figure A)
3. Locate the factory wiring harness in the dash. Metra recommends using the proper mating adapter from Metra or AXCESS.
4. Mount the new radio assembly into the dash and reassemble dash in reverse order of disassembly.

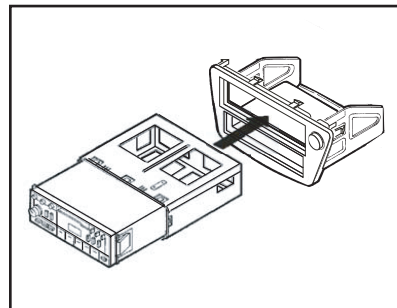

(Figure A)



Installation instructions for 99-7867



Kit Assembly 99-7867

ISO DIN radio provision with pocket

1. Mount the ISO brackets to the radio using the screws supplied with the radio. (Figure A)
2. Slide the radio into the radio housing until the ISO brackets snap into place. (Figure A)
3. Snap the trim plate onto the front of the radio housing. (Figure A)
4. Locate the factory wiring harness in the dash. Metra recommends using the proper mating adapter from Metra or AXCESS.
5. Mount the new radio assembly into the dash and reassemble dash in reverse order of disassembly.

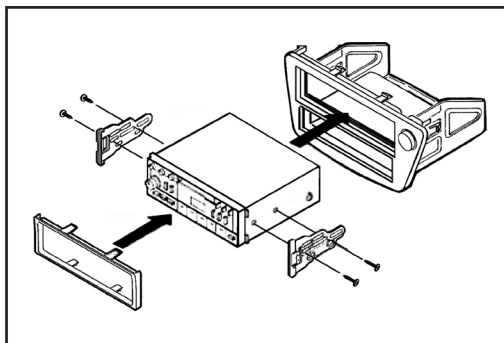

(Figure A)



KNOWLEDGE IS POWER

Enhance your installation and fabrication skills by enrolling in the most recognized and respected mobile electronics school in our industry. Log onto www.installerinstitute.com or call 800-354-6782 for more information and take steps toward a better tomorrow.



Metra recommends MECP certified technicians